

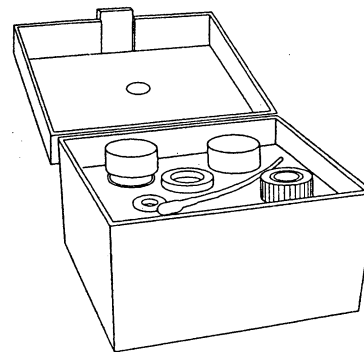

# CT485B-CAL-KIT

## Calibration Kit for CT485B Chart Recorder



INSTRUCTION  
SHEET

M2131/0295  
12039A1-99

### Unpacking Instructions

Remove the Packing List and verify that you have received all equipment, including the following (quantities in parentheses):

Bottle containing approximately 15g of ACS reagent-grade Magnesium Chloride ( $MgCl_2$ ) to produce 33% RH (1)

Bottle containing approximately 15g of ACS reagent-grade Sodium Chloride ( $NaCl$ ) to produce 75% RH (1)

Foam block to hold bottles upright, for testing, and to stabilize the temperature (1)

Fitter Cap (2)

Nylon washer (2)

O-Ring (2)

Liquid dropper (1)

Instruction sheet (1)

If you have any questions about the shipment, please call the OMEGA Customer Service Department.

When you receive the shipment, inspect the container and equipment for signs of damage. Note any evidence of rough handling in transit. Immediately report any damage to the shipping agent.

#### NOTE

The carrier will not honor damage claims unless all shipping material is saved for inspection. After examining and removing contents, save packing material and carton in the event reshipment is necessary.

### Introduction

The RH Calibration Kit provides an accurate method for calibrating the relative humidity sensor. The procedure is based on using selected saturated salt solutions to produce a known RH. The method is described in detail in the ASTM standard E104-85 "Standard Practice For Maintaining Constant Relative Humidity by Means of Aqueous Solutions".

### Preparation of Salt Solutions

#### NOTE

Follow all instructions very carefully. Allow 12 hours before calibrating the recorder.

#### NOTE

Prepare solutions with pure distilled water only (may be purchased at local supermarket).

1. Using the liquid dropper, add distilled water to the Magnesium Chloride ( $MgCl_2$ ) bottle, stirring after each addition until the salts can absorb no more liquid, as will be evidenced by a film of free liquid. Excess water should be suctioned off by using the liquid dropper.
2. Replace the cap on bottle and insert the bottle in the foam block for temperature stabilization.
3. Follow the same procedure for the bottle containing Sodium Chloride ( $NaCl$ ). The solutions should be prepared at least 12 hours prior to first-time use only. Thereafter, prepare solutions a minimum of one hour prior to use. (Preparation, at this time, will consist of either adding or pouring off liquid).

The relative humidity values of 33% and 75% are valid at 25°C (77°F). The following table lists the values at various room temperatures and should be used as the RH values in the actual calibration procedure.

Temperature	10°C	15°C	20°C	25°C	30°C	35°C	40°C
	(50°F)	(59°F)	(68°F)	(77°F)	(86°F)	(95°F)	(104°F)
Magnesium Chloride (MgCl <sub>2</sub> )	33.5%	33.3%	33.1%	32.8%	32.4%	32.1%	31.6%
Sodium Chloride (NaCl)	75.7%	75.6%	75.5%	75.3%	75.1%	74.9%	74.7%

(These values are published by NIST, Vol 81A, 1977, p 89-96, "Humidity Fixed Points of Binary Saturated Aqueous Solutions" by L. Greenspan).

**NOTE**

The sensor and solutions should be at the same uniform stable temperature before starting calibration.

**Calibration Setup for the CT485B Sensor**

1. First, read Section 5 of the CT485B manual starting on Page 5-1. Connect the sensor to the CT485B recorder as shown on Page 2-12 of the manual.
2. Insert the sensor through the fitter cap and then position the O-ring on the sensor tube approximately 1-1/4" from the end, as shown in Figure 1 (at the right).
3. Position the nylon washer so that the O-ring lies between the washer and the fitter cap as shown.
4. Screw the fitter cap assembly to the 33%RH magnesium chloride salt solution bottle in the foam block as shown. The sensor should **not** touch the salt solution.
5. Refer to the CT485B manual for the calibration procedure (Section 5.3.1 - Steps 1 through 3) starting on Page 5-6.
6. After completing Step 3 (in Section 5.3.1), unscrew the fitter cap assembly from the 33%RH solution. Re-cap the solution with the white cap.
7. Screw the fitter cap assembly to the 75%RH sodium chloride salt solution bottle in the foam block.
8. Complete the calibration procedure starting with Step 4 of Section 5.3.1 in the manual (Page 5-6) and ending on Page 5-7.
9. Remove the fitter assembly from the 75%RH salt solution and re-cap the bottle with the white cap.

End of procedure.

**NOTE:** if you desire NIST traceability, it is suggested that you call our Sales Department and send the recorder to OMEGA for calibration.

**Servicing USA and Canada: Call OMEGA Toll Free****USA**

One Omega Drive, Box 4047  
Stamford, CT 06907-0047  
Telephone: (203) 359-1660  
FAX: (203) 359-7700

**Canada**

976 Bergar  
Laval (Quebec) H7L 5A1  
Telephone: (514) 856-6928  
FAX: (514) 856-6886

Sales Service: 1-800-826-6342 / 1-800-TC-OMEGA™  
Customer Service: 1-800-622-2378 / 1-800-622-BEST™  
Engineering Service: 1-800-872-9436 / 1-800-USA-WHEN™  
TELEX: 996404 EASYLINK: 62968934 CABLE: OMEGA

**Servicing Europe: United Kingdom Sales and Distribution Center**

25 Swannington Road, Broughton Astley, Leicestershire  
LE9 6TU, England  
Telephone: 44 (1455) 285520 FAX: 44 (1455) 283912

FOR CT485B  
Use smaller  
O-ring  
ID washer  
ID cap

CT485B-220V  
Uses larger  
O-ring  
ID washer  
ID cap

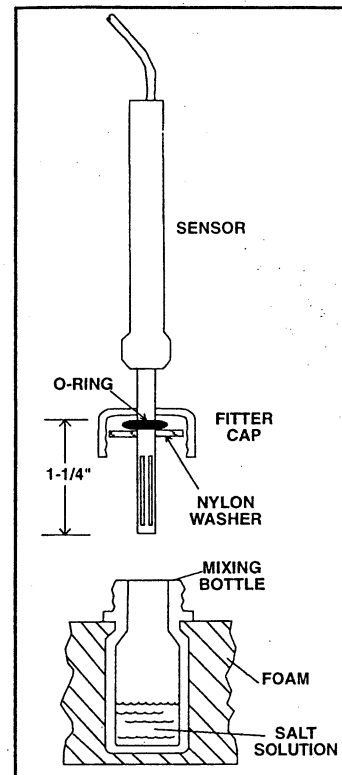

Figure 1. Parts of the Cal Kit

MADE  
USA**WARRANTY/DISCLAIMER**

OMEGA is glad to offer suggestions on the use of its various products. Nevertheless, OMEGA only warrants that the parts manufactured by it will be as specified and free of defects.

OMEGA MAKES NO OTHER WARRANTIES OR REPRESENTATIONS OF ANY KIND WHATSOEVER, EXPRESSED OR IMPLIED, EXCEPT THAT OF TITLE AND ALL IMPLIED WARRANTIES INCLUDING ANY WARRANTY OF MERCHANTABILITY AND FITNESS FOR A PARTICULAR PURPOSE ARE HEREBY DISCLAIMED.

**LIMITATION OF LIABILITY:** The remedies of purchaser set forth herein are exclusive and the total liability of OMEGA with respect to this order, whether based on contract, warranty, negligence, indemnification, strict liability or otherwise, shall not exceed the purchase price of the component upon which liability is based. In no event shall OMEGA be liable for consequential, incidental or special damages.

Every precaution for accuracy has been taken in the preparation of this manual; however, OMEGA ENGINEERING, INC. neither assumes responsibility for any omissions or errors that may appear nor assumes liability for any damages that result from the use of the products in accordance with the information contained in the manual.

**SPECIAL CONDITION:** Should this equipment be used in or with any nuclear installation or activity, purchaser will indemnify OMEGA and hold OMEGA harmless from any liability or damage whatsoever arising out of the use of the equipment in such a manner.

**RETURN REQUESTS / INQUIRIES**

BEFORE RETURNING ANY PRODUCT(S) TO OMEGA, PURCHASER MUST OBTAIN AN AUTHORIZED RETURN (AR) NUMBER FROM OMEGA'S CUSTOMER SERVICE DEPARTMENT (IN ORDER TO AVOID PROCESSING DELAYS). The assigned AR number should then be marked on the outside of the return package and on any correspondence.

OMEGA's policy is to make running changes, not model changes, whenever an improvement is possible. This affords our customers the latest in technology and engineering.

OMEGA is a registered trademark of OMEGA ENGINEERING, INC.

© Copyright 1995 OMEGA ENGINEERING, INC. All rights reserved. This documentation may not be copied, photocopied, reproduced, translated, or reduced to any electronic medium or machine-readable form, in whole or in part, without prior written consent of OMEGA ENGINEERING, INC.