

OPERATION

Step 1. Apply Power to the Instrument

When your device is first powered up it will display the ambient temperature (assume 75°F).

Step 2. Enter Setpoint 1 Menu

Press **⏸** one time from run mode to get to **SP1** Setpoint 1.

Step 3. Enter the Setpoint 1 Value Submenu

Press **⏸**. Display shows the previous selection of Setpoint 1.

Step 4. Change the Setpoint 1 Value

Press **▲** or **▼** until desired value is displayed.

Step 5. Store the Setpoint 1 Value

Set the Setpoint 1 to 10 degree higher than Process value (SP1 = 85) and press **⏸** to store, display flashes **SErD** message and advances to **SP2** Setpoint 2 Menu.

Step 6. Store the Setpoint 2 Value

Repeat steps 3 and 4. Set the Setpoint 2 to 5 degree higher than Process value (SP2 = 80) and press **⏸** to store, display flashes **SErD** message and advances to **ENFG** Configuration Menu.

Step 7. Enter the Reading Config Menu

Press **⏸** to enter **RdG** Reading Config Menu.

Step 8. Enter the submenu items of Rdg Config Menu

Press **⏸** to display **SENSR** Sensor submenu: Sensor selection for Autotune, Loop, or Ramp and Soak **F.T.C** is for temperature and **o.PRH** is for Humidity

Step 9. Enter the submenu items of Rdg Config Menu

Press **⏸** to display Temp Unit submenu:

Step 10 Scroll thru selection for Temp Unit submenu

Press **⏸** to Scroll through the available selections of the Temperature Unit of your choice: **F** or **C**.

Step 11. Store the Temperature Unit

Press **⏸**, display momentarily shows **SErD** the Unit has been stored and the instrument will go automatically to the next menu item.

Step 12. Enter the Filter Constant Submenu

Display shows **FLTR** Filter Constant Submenu.

Step 13. Display the Filter Constant Value Submenu

Press **⏸** to display the flashing, previously selected Filter Constant.

Step 14. Scroll through available Filter Constants

Press **▲** to sequence thru Filter Constants **0001**, **0002**, **0004**, **0008**, **0016**, **0032**, **0064** and **0128**.

Step 15. Store the Filter Constant

Press **⏸** momentarily to store **0004** Filter Constant and the instrument will automatically go to the next menu item.

Step 16. Enter Alarm 1 Menu

The display will show **ALR1** the top menu for Alarm 1. In the following steps we are going to enable Alarm 1, Deviation, Unlatch, Normally Open, Active Above, Enable at power-on and +2°F High Alarm i.e. Process Value > Setpoint 1 Value +2°F will activate Alarm 1.

- If Analog Output Option is installed and enabled, the controller will skip Alarm 1 Menu item to Analog Output.
- Alarm must be DISABLED if Ramp is ENABLED.
- Alarm1 will only work for Humidity, not Temperature.

Alarm 1 is designed to monitor the humidity value around Setpoint 1 and Alarm 2 is designed to monitor the temperature value around Setpoint 2.

Step 17. Enter Alarm 1 Enable/Disable Submenu

Press **⏸** to display flashing **ENBL** / **ENBL**.

Step 18. Enable Alarm 1 Submenu

If flashing **ENBL** is displayed, press **⏸**, if **DSBL** is displayed, press **▲** until **ENBL** is displayed, then press **⏸** to store and go to the next menu item.

Step 19. Select the Deviation Control Type Submenu

Press **⏸**. If flashing **DEV** Deviation is displayed press **⏸**, otherwise press **▲** until flashing **DEV** is shown. Now press **⏸** to store and go to next menu item.

Step 20. Select the Latched Type Submenu

Press **⏸**. If flashing **UNL** Unlatched is displayed press **⏸**, otherwise press **▲** until **UNL** is displayed. Press **⏸** to store and advance to next menu item.

Step 21. Select the Normally Open Type of Contact Closure Submenu

Press **⏸**. If flashing **N.O.** Normally Open is displayed, press **⏸**, otherwise press **▲** until **N.O.** is displayed. Press **⏸** to store and advance to next menu item.

Step 22. Select the Above Type of Active Submenu

Press **⏸**. If flashing **ABOV** Above is displayed, press **⏸**, otherwise press **▲** until **ABOV** is displayed. Press **⏸** to store and advance to next menu item.

Step 23. Enable Alarm 1 at Power On (R.P.O.N)

Press **⏸**. If flashing **ENBL** is displayed, press **⏸**, otherwise press **▲** until **ENBL** is displayed. Press **⏸** to store and advance to next menu item.

Step 24. Enter Alarm 1 High Submenu

Press **⏸** twice to skip **ALR.L** Alarm 1 Low value. **ALR.L** is for below & **ALR.H** for above.

Step 25. Set the Alarm 1 High value (ALR.H)

Press **⏸**. Press **▲** or **▼** until value to set the display to **002.0**. Press **⏸** to save.

Step 26. Enter the Alarm 2 Menu

The display will show **ALR2** the top menu for Alarm 2. Repeat steps from 17 to 25 to set for Alarm 2 the same conditions as for Alarm 1.

Step 29. Configuration of Display Color Selection

Press **⏸** until the **COLR** Display Color Selection Menu appears on the Display. Configure **COLR** as **NCLR** / **GRN** (green), **ICLR** / **RED** (red), **ELCR** / **AMBR** (amber). Please refer to the operator's manual if needed.

For color change on Setpoints refer to Owners Manual Section 2.

SPECIFICATION

SENSOR SPECIFICATIONS

Relative Humidity Accuracy/Range:

±2% for 10 to 90%
±3% for 5 to 10% and 90 to 95%
±4% for 0 to 5% and 95 to 100%

Non-linearity: ±3%

Hysteresis: ±1% RH

Response Time:

8 sec, tau 63%

Repeatability: ±0.1%

Resolution: 0.1%, 12bit

Temperature Accuracy/Range*:

±0.5°C for 5 to 45°C (±1°F for 41 to 113°F);
up to ±1.5°C for -40 to 5°C and 45 to 124°C
(up to ±2.7°F for -40 to 41°F and 113 to 257°F)

*NOTE: extended temp range is for Probe only, the Controller's operating temp is 0-50°C

Response Time:

5 to 30 sec, tau 63%

Repeatability: ±0.1°C

Resolution: 0.1°C, 14 bit

METER SPECIFICATIONS

Display:

4-digit, 9-segment LED,
• 10.2 mm (0.40")
Red, green, and amber programmable colors for setpoint and temperature units.

Output 1*:

Relay 250 Vac @ 3 A Resistive Load,
SSR, Pulse

Output 2*:

Relay 250 Vac @ 3 A Resistive Load,
SSR, Pulse

* Only with -AL Limit Alarm option

Options: Communication

RS-232 / RS-485 or 10BaseT
or Excitation: 24 Vdc @ 25 mA

Exc. not available for Low Power Option

Line Voltage/Power:

90 - 240 Vac ±10%, 50 - 400 Hz*,
or 110 - 375 Vdc, 5 W
* No CE compliance above 60 Hz

Low Voltage Power Option:

20 - 36 Vdc or 24 Vac** ±10%, 4 W
** Units can be powered safely with 24 Vac
but No Certification for CE/UL are claimed.

Dimensions:

48H x 48W x 127D mm

(1.89 x 1.89 x 5")

Weight:

159 g (0.35 lb)

Approvals:

UL, C-UL, CE per EN61010-1:2001

WARNING: These products are not designed for use in, and should not be used for, patient-connected applications.

! This device is marked with the international caution symbol. It is important to read the Setup Guide before installing or commissioning this device, as the guide contains important information relating to safety and EMC.

It is the policy of NEWPORT to comply with all worldwide safety and EMC/EMI regulations that apply. NEWPORT is constantly pursuing certification of its products to the European New Approach Directives. NEWPORT will add the CE mark to every appropriate device upon certification.

The information contained in this document is believed to be correct, but NEWPORT Electronics, Inc. accepts no liability for any errors it contains, and reserves the right to alter specifications without notice.

TRADEMARK NOTICE:

N, **N NEWPORT**, **NEWPORT**, newportUS.com, and the "Meter Bezel Design" are Trademarks of NEWPORT ELECTRONICS, INC.

WARRANTY/DISCLAIMER

NEWPORT Electronics, Inc. warrants this unit to be free of defects in materials and workmanship for a period of **one (1) year** from the date of purchase. In addition to NEWPORT's standard warranty period, NEWPORT Electronics will extend the warranty period for **four (4) additional years** if the warranty card enclosed with each instrument is returned to NEWPORT.

If the unit malfunctions, it must be returned to the factory for evaluation. NEWPORT's Customer Service Department will issue an Authorized Return (AR) number immediately upon phone or written request. Upon examination by NEWPORT, if the unit is found to be defective, it will be repaired or replaced at no charge. NEWPORT's WARRANTY does not apply to defects resulting from any action of the purchaser, including but not limited to mishandling, improper interfacing, operation outside of design limits, improper repair, or unauthorized modification. This WARRANTY is VOID if the unit shows evidence of having been tampered with or shows evidence of having been damaged as a result of excessive corrosion; or current, heat, moisture or vibration; improper specification; misapplication; misuse or other operating conditions outside of NEWPORT's control. Components which wear are not warranted, including but not limited to contact points, fuses, and triacs.

NEWPORT is pleased to offer suggestions on the use of its various products. However, NEWPORT neither assumes responsibility for any omissions or errors nor assumes liability for any damages that result from the use of its products in accordance with information provided by NEWPORT, either verbal or written. NEWPORT warrants only that the parts manufactured by it will be as specified and free of defects.

NEWPORT MAKES NO OTHER WARRANTIES OR REPRESENTATIONS OF ANY KIND WHATSOEVER, EXPRESS OR IMPLIED, EXCEPT THAT OF TITLE, AND ALL IMPLIED WARRANTIES INCLUDING ANY WARRANTY OF MERCHANTABILITY AND FITNESS FOR A PARTICULAR PURPOSE ARE HEREBY DISCLAIMED.

LIMITATION OF LIABILITY: The remedies of purchaser set forth herein are exclusive, and the total liability of NEWPORT with respect to this order, whether based on contract, warranty, negligence, indemnification, strict liability or otherwise, shall not exceed the purchase price of the component upon which liability is based. In no event shall NEWPORT be liable for consequential, incidental or special damages.

CONDITIONS: Equipment sold by NEWPORT is not intended to be used, nor shall it be used: (1) as a "Basic Component" under 10 CFR 21 (NRC), used in or with any nuclear installation or activity; or (2) in medical applications or used on humans. Should any Product(s) be used in or with any nuclear installation or activity, medical application, or used on humans, or misused in any way, NEWPORT assumes no responsibility as set forth in our basic WARRANTY/DISCLAIMER language, and, additionally purchaser will indemnify NEWPORT and hold NEWPORT harmless from any liability or damage whatsoever arising out of the use of the Product(s) in such a manner.

RETURN REQUEST/INQUIRIES

Direct all warranty and repair requests/inquiries to the NEWPORT Customer Service Department. BEFORE RETURNING ANY PRODUCT(S) TO NEWPORT, PURCHASER MUST OBTAIN AN AUTHORIZED RETURN (AR) NUMBER FROM NEWPORT'S CUSTOMER SERVICE DEPARTMENT (IN ORDER TO AVOID PROCESSING DELAYS). The assigned AR number should then be marked on the outside of the return package and on any correspondence.

The purchaser is responsible for shipping charges, freight, insurance and proper packaging to prevent breakage in transit.

FOR WARRANTY RETURNS, please consult NEWPORT for current repair BEFORE contacting NEWPORT:

1. Purchase Order number under which the product was PURCHASED.
2. Model and serial number of the product under warranty, and
3. Repair instructions and/or specific problems relative to the product.

FOR NON-WARRANTY REPAIRS, have the following information available BEFORE contacting NEWPORT:

1. Purchase Order number to cover the COST the repair,
2. Model and serial number of product, and
3. Repair instructions and/or specific problems relative to the product.

NEWPORT's policy is to make running changes, not model changes, whenever an improvement is possible. This affords our customers the latest in technology and engineering.

NEWPORT is a registered trademark of NEWPORT Electronics, Inc.

© Copyright 2011 NEWPORT Electronics, Inc. All rights reserved.

This document may not be copied, photocopied, reproduced, translated, or reduced to any electronic medium or machine-readable form, in whole or in part, without the prior written consent of NEWPORT Electronics, Inc.

PATENT NOTICE: This product is covered by one or more of the following patents: U.S. Pat. No. Des. 336,895; 5,274,577; 6,243,021 / Canada 2052599; 2052600 / Italy 1249456; 1250938 / France Brevet No. 91 12756 / Spain 2039159; 2048066 / UK Patent No. GB2 249 837; GB2 248 954 / Germany DE 41 34398 C2. The **N** is a Trademark of OMEGA Engineering, Inc. USED UNDER LICENSE. Other U.S. and International patents pending or applied for.



iSeries iTH-i16D Humidity + Temperature Monitor / Limit Alarm (-AL)

For immediate technical or application assistance please call:

1-800-6397678
1-800-NEWPORT

Newport Electronics, Inc.
2229 South Yale Street • Santa Ana, CA • 92704 • U.S.A.
TEL: (714) 450-4914 • FAX: (203) 968-7311
Toll Free: 1-800-639-7678 • www.newportUS.com • e-mail: info@newportUS.com
ISO 9001 Certified

Newport Technologies, Inc.
976 Bergar • Laval (Quebec) • H7L 5A1 • Canada
TEL: (514) 335-3183 • FAX: (514) 856-6886
Toll Free: 1-800-639-7678 • www.newport.ca • e-mail: info@newport.ca

Newport Electronics, Ltd.
One Omega Drive • River Bend Technology Centre
Northbank, Irlam • Manchester M44 5BD • United Kingdom
Tel: +44 161 777 6611 • FAX: +44 161 777 6622
Toll Free: 0800 488 488 • www.newportuk.co.uk • e-mail: sales@newportuk.co.uk

Newport Electronics B.V. - Benelux
Managed by the United Kingdom Office
TEL: +31 20 3472121 • FAX: +31 20 6434643
Toll Free: 0800 0993344 • www.newport.nl • e-mail: info@newport.nl

Newport Electronics spol s.r.o.
Frystatska 184, 733 01 Karviná • Czech Republic
TEL: +420 59 6311899 • FAX: +420 59 6311114
Toll Free: 0800-1-66342 • www.newport.cz • e-mail: info@newport.cz

Newport Electronics GmbH
Daimlerstrasse 26 • D-75392 Deckenpfronn • Germany
TEL: 49 7056 9398-0 • FAX: 49 7056 9398-29
Toll Free: 0800 / 6397678 • www.newport.de • e-mail: sales@newport.de

Newport Electronique S.A.R.L. - France
Managed by the United Kingdom Office
TEL: +33 1 61 37 29 00 • FAX: +33 1 30 57 54 27
Toll Free: 0800 466 342 • www.newport.fr • e-mail: sales@newport.fr

Mexico and Latin America
FAX: 001 (203) 359-7807
TEL En Español: 001 (203) 359-7803

NEWPORTnet™ On-Line Service
www.newportUS.com

Internet e-mail
info@newportUS.com

N NEWPORT Electronics, Inc.



This Quick Start Reference provides information on setting up your instrument for basic operation. The latest complete Communication and Operational Manual as well as free Software and ActiveX Controls are available at www.newportUS.com/i or on the CD-ROM enclosed with your shipment.

SAFETY CONSIDERATION



This device is marked with the international Caution symbol.

The instrument is a panel mount device protected in accordance with EN61010-1:2001. Remember that the unit has no power-on switch. Building installation should include a switch or circuit-breaker that must be compliant to IEC 947-1 and 947-3.

SAFETY:

- Do not exceed voltage rating on the label located on the top of the instrument housing.
- Always disconnect power before changing signal and power connections.
- Do not use this instrument on a work bench without its case for safety reasons.
- Do not operate this instrument in flammable or explosive atmospheres.
- Do not expose this instrument to rain or moisture.

EMC:

- Whenever EMC is an issue, always use shielded cables.
- Never run signal and power wires in the same conduit.
- Use signal wire connections with twisted-pair cables.
- Install Ferrite Bead(s) on signal wire close to the instrument if EMC problems persist.

MOUNTING

Panel Mounting Instruction:

- Using the dimensions from the panel cutout shown in exploded views, cut an opening in the panel. 45mm +.61/-0.00 square with R 1.5, 4 places (1.772" +.024/-0.000 square with R 0.06", 4 places) Panel thickness: 6.4mm (0.25") max / 0.8mm (0.03") min.
- Insert the unit into the opening from the front of the panel, so the gasket seals between the bezel and the front of the panel.
- Slide the retainer over the rear of the case and tighten against the backside of the mounting panel.

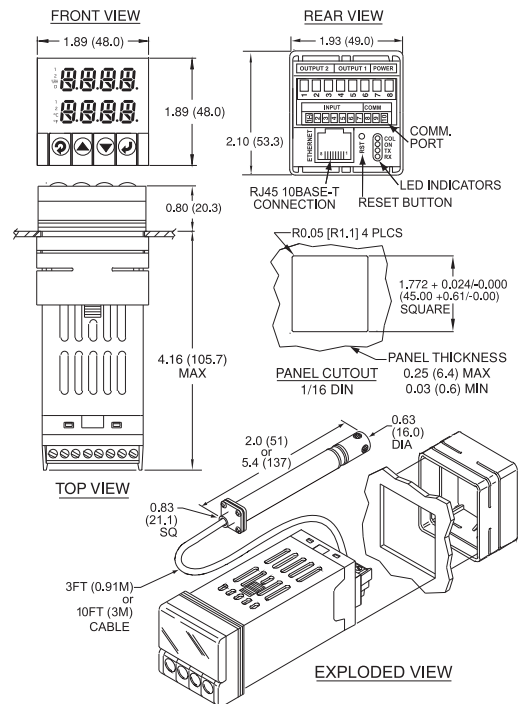

Disassembly Instruction: If necessary, the unit may be removed from the panel and opened.



Warning: Disconnect all ac power from the unit before proceeding.

- Make sure the AC power is disconnected.
- Remove all wiring connections from the rear of the meter. To remove power and input connectors squeeze top and bottom of the case near the connector site for release, then pull connectors from the case.
- To remove meter from the case, squeeze top and bottom of the bezel to release, then pull from case.

WIRING

Wire the instrument according to the figure shown below.



Warning: Do not connect ac power to your device until you have completed all input and output connections. This device must only be installed by a specially trained electrician with corresponding qualifications. Failure to follow all instructions and warnings may result in injury!

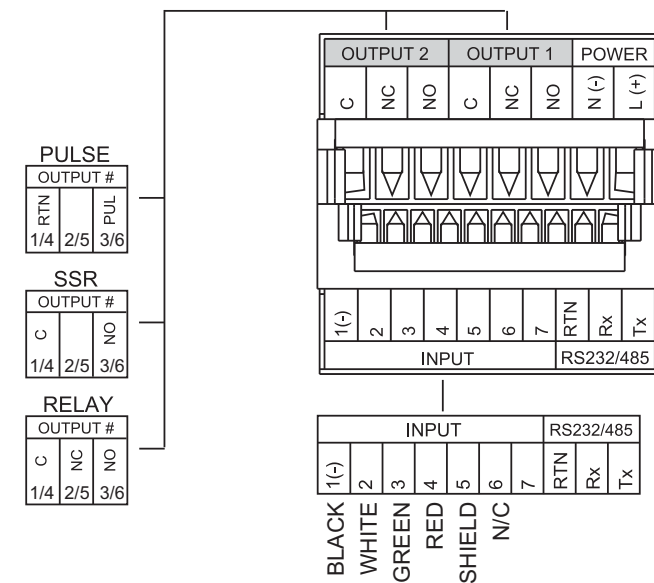

Note: Refer to Operator's Manual for important Input Probe Shield wiring notes

Connect the main power connections as shown in the figure below

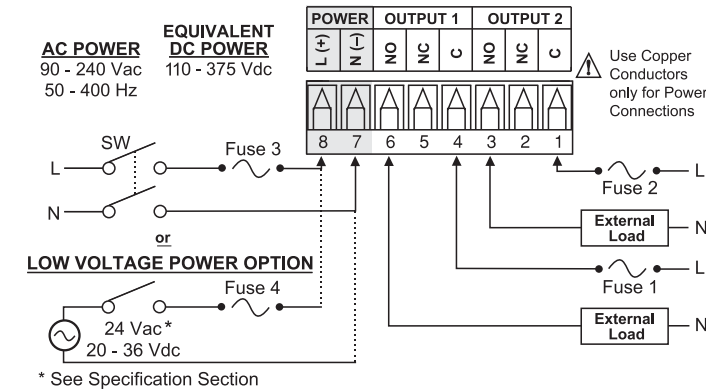

Note: Output 1 and 2 are for -AL Limit Alarm Option only.

FUSE	Connector	Output Type	For 115Vac	For 230Vac	DC
FUSE 1	Output 1	Relay	3 A(T)	3 A(T)	-
FUSE 2	Output 2	Relay	3 A(T)	3 A(T)	-
FUSE 3	Power	N/A	100 mA(T)	100 mA(T)	100 mA(T)
FUSE 4	Power	N/A	N/A	N/A	400 mA(T)

DESCRIPTION OF FRONT PANEL

The upper display may be RH, Temperature or Dewpoint readings depending on your Reading Configuration selections. Factory defaults are shown. The Dual Display allows the user to observe the Relative Humidity or Dewpoint (upper display) and Temperature Value (lower display), at the same time.

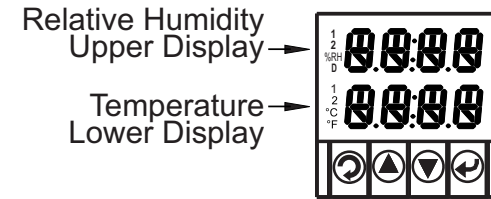

1	Output 1/Setpoint 1/ Alarm 1 indicator
2	Output 2/Setpoint 2/ Alarm 2 indicator
°C	°C unit indicator for Temperature or Dewpoint
°F	°F unit indicator for Temperature or Dewpoint
%RH	Display shows the Percent Relative Humidity
D	Display shows the Dewpoint
⏪	Changes display to Configuration Mode and advances through menu items*
⏩	Used in Program Mode:
⏴	Used in Program Mode:
⏵	Accesses submenus in Configuration Mode and stores selected values*

CONFIGURATION

The instrument has two different modes of operation. **Run Mode:** used to display Temperature and Relative Humidity. **Menu Configuration Mode:** used to navigate through the menu options and configure the controller.

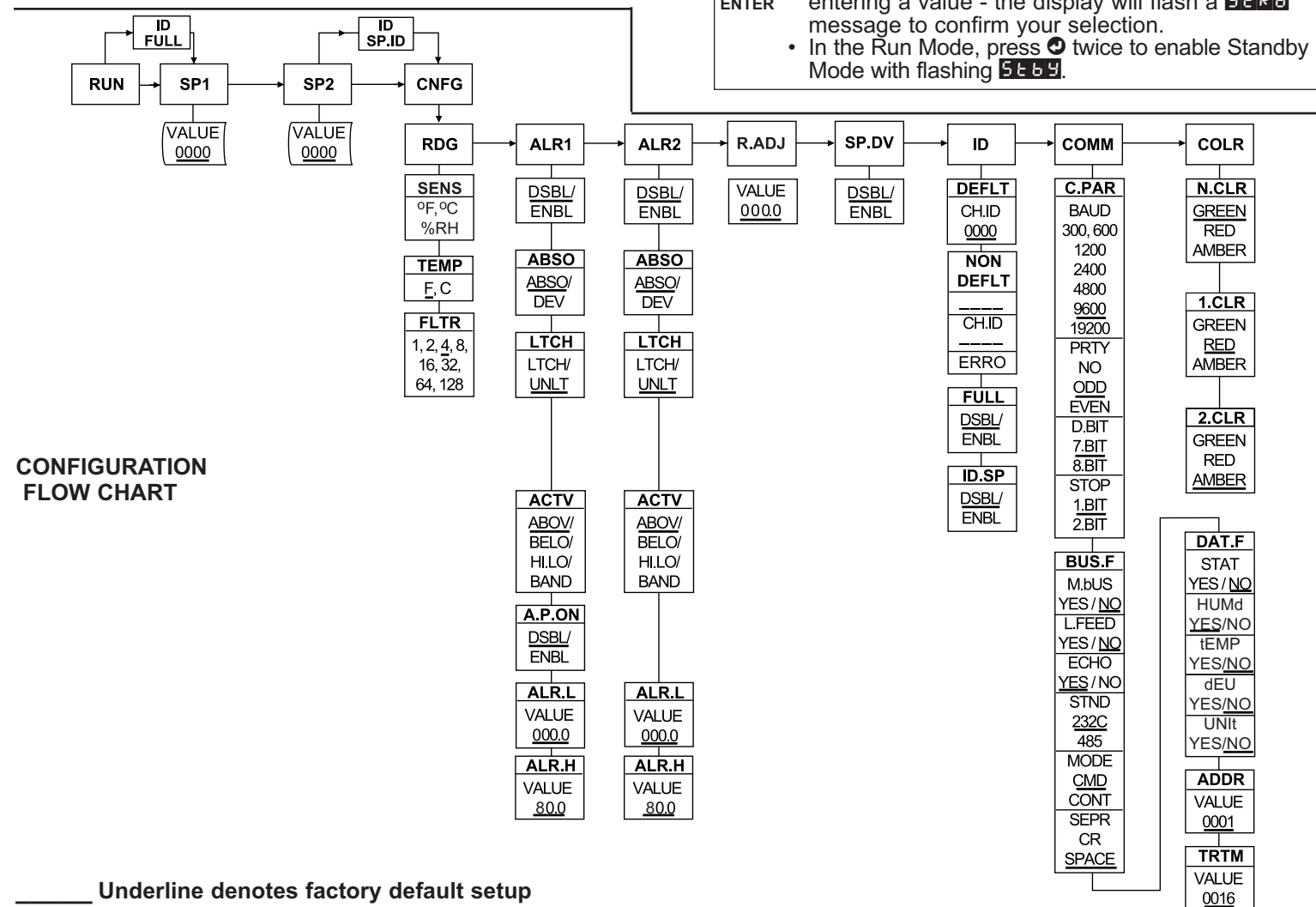

Underline denotes factory default setup

Button Function in Configuration Mode

- MENU**
 - To enter the Menu, the user must first press **⏪** button.
 - Use this button to advance/navigate to the next menu item. The user can navigate through all the top level menus by pressing **⏪**.
 - While a parameter is being modified, press **⏪** to escape without saving the parameter.
- (UP)**
 - Press the up **⏴** button to scroll through "flashing" selections. When a numerical value is displayed press this key to increase value of a parameter that is currently being modified.
 - Pressing the **⏴** button for approximately 3 seconds will speed up the rate at which the set point value increments.
 - In the Run Mode, pressing the **⏴** button changes display from RH readings to Temperature readings.
- (DOWN)**
 - Press the down **⏵** button to go back to a previous Top Level Menu item.
 - Press this button twice to reset the controller to the Run Mode.
 - When a numerical value is flashing (except set point value) press **⏵** to scroll digits from left to right allowing the user to select the desired digit to modify.
 - When a setpoint value is displayed press **⏵** to decrease value of a setpoint that is currently being modified. Pressing the **⏵** button for approximately 3 seconds will speed up the rate at which the setpoint value is decremented.
 - In the Run Mode, pressing the **⏵** button changes from RH readings to Dewpoint readings.
- ENTER**
 - Press the enter **⏵** button to access the submenus from a Top Level Menu item.
 - Press **⏵** to store a submenu selection or after entering a value - the display will flash a **ST.RD** message to confirm your selection.
 - In the Run Mode, press **⏵** twice to enable Standby Mode with flashing **STBY**.