

# iSeries™



## Embedded Ethernet Server for iSeries Monitor/Controller

### Operator's Manual



**N**® **NEWPORT** Electronics, Inc.  
<http://www.newportUS.com/iServer>

Additional products from

# **NEWPORT** Electronics, Inc.

Counters	Rate Meters
Frequency Meters	Timers
PID Controllers	Totalizers
Clock/Timers	Strain Gauge Meters
Printers	Voltmeters
Process Meters	Multimeters
On/Off Controllers	Soldering Iron Testers
Recorders	pH pens
Relative Humidity	pH Controllers
Transmitters	pH Electrodes
Thermocouples	RTDs
Thermistors	Thermowells
Wire	Flow Sensors

For Immediate Assistance  
In the U.S.A. and Canada: 1-800-NEWPORT<sup>®</sup>  
In Mexico: (95) 800-NEWPORT<sup>SM</sup>  
Or call your local NEWPORT Office.

**NEWPORTnet<sup>SM</sup> On-Line Service**  
[www.newportUS.com](http://www.newportUS.com)

**Internet e-mail**  
[info@newportUS.com](mailto:info@newportUS.com)

It is the policy of NEWPORT to comply with all worldwide safety and EMC/EMI regulations that apply. NEWPORT is constantly pursuing certification of its products to the European New Approach Directives. NEWPORT will add the CE mark to every appropriate device upon certification.

The information contained in this document is believed to be correct but NEWPORT Electronics, Inc. accepts no liability for any errors it contains, and reserves the right to alter specifications without notice.

**WARNING:** These products are not designed for use in, and should not be used for, patient connected applications.

**TRADEMARK NOTICE:** ,  **NEWPORT**, **NEWPORT**<sup>®</sup>, and the "Meter Bezel Design" are trademarks of NEWPORT Electronics, Inc.

**PATENT NOTICE:** This product is covered by one or more of the following patents: U.S. Pat. No. Des. 336,895; 5,274,577 / CANADA 2052599; 2052600 / ITALY 1249456; 1250938 / FRANCE BREVET No. 91 12756 / SPAIN 2039150; 2048066 / UK PATENT No. GB2 249 837; GB2 248 954 / GERMANY DE 41 34398 C2. The  is a Trademark of OMEGA Engineering, Inc. Used Under License. Other US and International Patents pending or applied for.



This device is marked with the international caution symbol. It is important to read the Setup Guide before installing or commissioning this device as it contains important information relating to safety and EMC.

# TABLE OF CONTENTS

<b>Part 1: Introduction</b> .....	<b>2</b>
1.1 Safety and EMC Considerations .....	2
1.2 Before You Begin .....	3
1.3 Description .....	4
<b>Part 2: Hardware</b> .....	<b>5</b>
2.1 Physical Characteristics and Mounting .....	5
2.2 Rear Panel of iSeries Meter with Embedded Ethernet Server .....	5
2.3 Serial Communication Interfaces .....	7
2.3.1 Wiring RS485 Interface .....	8
2.4 Network Communication Interfaces .....	9
2.4.1 10Base-T RJ-45 Pinout .....	9
2.4.2 10Base-T Crossover Wiring .....	9
<b>Part 3: Network Configuration</b> .....	<b>10</b>
3.1 Network Protocols .....	10
3.2 Ethernet (MAC) Address .....	10
3.3 IP Address .....	11
3.3.1 Default IP Address .....	11
3.4 Subnetting .....	11
3.5 Port Number .....	11
<b>Part 4: Serial Interface Configuration</b> .....	<b>12</b>
4.1 Communication Protocol .....	12
4.2 Command Structure .....	12
4.3 Command Formats .....	12
<b>Part 5: Operations</b> .....	<b>14</b>
5.1 Modifying the IP Address .....	14
5.2 HTTPGET Program .....	16
5.3 ARP Protocol .....	17
5.4 Setup and Operation using the iServer Web Page .....	19
5.4.1 Read Devices .....	20
5.4.2 Send Raw Command .....	21
5.4.3 Modify Device List Entry .....	21
5.4.4 Serial Port Configuration .....	22
5.4.5 Configure Access Control .....	23
5.4.6 Log In .....	24
5.4.7 Change ID .....	24
5.5 Mail Notifier Software .....	25
5.5.1 Installation .....	25
5.5.2 Program Options Setup and Configuration .....	26
5.5.3 Device Setting Setup and Configuration .....	27

Part 6: Specifications .....	28
Part 7: Factory Preset Values .....	29
Part 8: CE Approvals Information .....	30
Electromagnetic Compatibility (EMC) .....	30
FCC .....	30
Appendix A Glossary .....	31
Appendix B IP Address .....	32
Appendix C IP Netmask .....	33
Appendix D ASCII Chart .....	34
ASCII Chart Control Codes .....	35

**LIST OF FIGURES:**

Figure 1.1 Embedded Ethernet Server on the Ethernet Network .....	4
Figure 2.1 Rear Panel View of i16/i18 Meters w/Embedded Ethernet Server .....	5
Figure 2.2 Multi-point, Half-Duplex RS485 Wiring .....	8
Figure 2.3 RJ45 Connector Pinout .....	9
Figure 2.4 10Base-T Crossover Cable Wiring .....	9
Figure 3.1 i8 - Labeling .....	10
Figure 3.2 i16 - Labeling .....	11
Figure 5.1 arp -a Commands and Responses .....	18
Figure 5.2 iServer Home Page .....	19
Figure 5.3 iServer Mail Notifier Main Window .....	25
Figure 5.4 iServer Mail Notifier Profile Setup .....	26
Figure 5.5 iServer Mail Notifier Device Setting .....	27

**LIST OF TABLES:**

Table 2.1 Rear Panel Annunciators .....	6
Table 2.2 Characteristics of RS485 Communication Interfaces .....	7
Table 2.3 RS485 Half-Duplex Hookup .....	8
Table 4.1 Command Prefix Letters .....	12
Table 4.2 Command Formats .....	12

## NOTES, WARNINGS and CAUTIONS

Information that is especially important to note is identified by following labels:

- **NOTE**
- **WARNING or CAUTION**
- **IMPORTANT**
- **TIP**



**Note** E-S

**NOTE:** Provides you with information that is important to successfully setup and use the Programmable Digital Meter.



**CAUTION or WARNING:** Tells you about the risk of electrical shock.



**CAUTION, WARNING or IMPORTANT:** Tells you of circumstances or practices that can effect the instrument's functionality and must refer to accompanying documents.



**Tip** E-S

**TIP:** Provides you helpful hints.

# PART 1 INTRODUCTION

## 1.1 Safety Considerations



This device is marked with the **International Caution Symbol**. It is **important to read** this manual before installing or commissioning this device as it contains important information relating to **Safety and EMC** (Electromagnetic Compatibility).

This instrument is a **panel mount device** protected in accordance with **Class II** of EN 61010 (115/230 AC power connections), and **Class III** for the low voltage power option (12-36 Vdc or 24 Vac). Installation of this instrument should be done by qualified personnel.



This instrument has **no power-on switch**. An external **switch or circuit-breaker** shall be included in the building installation as a disconnecting device. It shall be marked to indicate this function, and it shall be in close proximity to the equipment within easy reach of the operator. The switch or circuit-breaker shall meet the relevant requirements of IEC 947-1 and IEC 947-3 (International Electrotechnical Commission). The switch shall not be incorporated in the main supply cord.



Furthermore, to provide protection against **excessive energy** being drawn from the main supply in case of a fault in the equipment, an **overcurrent** protection device shall be installed.



- Do not exceed voltage rating on the label located on the top of the instrument housing.
- Always disconnect power before changing signal and power connections.
- Do not use this instrument on a work bench without its case for safety reasons.
- Do not operate this instrument in flammable or explosive atmospheres.
- Do not expose this instrument to rain or moisture.
- Unit mounting should allow for adequate ventilation to ensure instrument does not exceed operating temperature rating.
- Use electrical wires with adequate size to handle mechanical strain and power requirements. Install without exposing bare wire outside the connector to minimize electrical shock hazards.

## EMC Considerations

- Whenever EMC is an issue, always use shielded cables.
- Never run signal and power wires in the same conduit.
- Use signal wire connections with twisted-pair cables.
- Install Ferrite Bead(s) on signal wires close to the instrument if EMC problems persist.

**Failure to follow all instructions and warnings may result in injury!**

## 1.2 Before You Begin

### Inspecting Your Shipment:

Remove the packing slip and verify that you have received everything listed. Inspect the container and equipment for signs of damage as soon as you receive the shipment. Note any evidence of rough handling in transit. Immediately report any damage to the shipping agent. The carrier will not honor damage claims unless all shipping material is saved for inspection. After examining and removing the contents, save the packing material and carton in the event reshipment is necessary.

### Customer Service:

If you need assistance, please contact the Customer Service Department nearest you.

### Manuals, Software:

The latest Operation Manual as well as free iSeries configuration software and Web Server Mail Notifier are available at **the website listed on the cover page of this manual or on the CD-ROM enclosed in your shipment.**

### 1.3 Description

**Note**

This device can be purchased as a stand alone DIN Rail mounted unit, or as an option for an iSeries monitor/controller (Embedded Ethernet Server) with a RS485 communication port interface. Some iSeries monitors/controllers do not utilize RS485 communications. In such models, the RS485 instructions do not apply.

The Embedded Ethernet Server is designed to connect industrial devices with serial interfaces to the Ethernet network using the TCP/IP protocol. It contains an Ethernet Server and RS-485/422 interfaces.

The standard features include:

- Use standard Web Browser (TCP/IP protocol) or HTTPGET DOS program for network connectivity.
- Install via RS-485/422 serial port connection.
- Transfer data from RS-485/422 serial interface to TCP/IP using built-in socket server.
- Use a standard home page or customize web page using special applets, which are available on our Web site.

The following example illustrates how you can hookup the devices with serial interface on the net using the Ethernet Server:

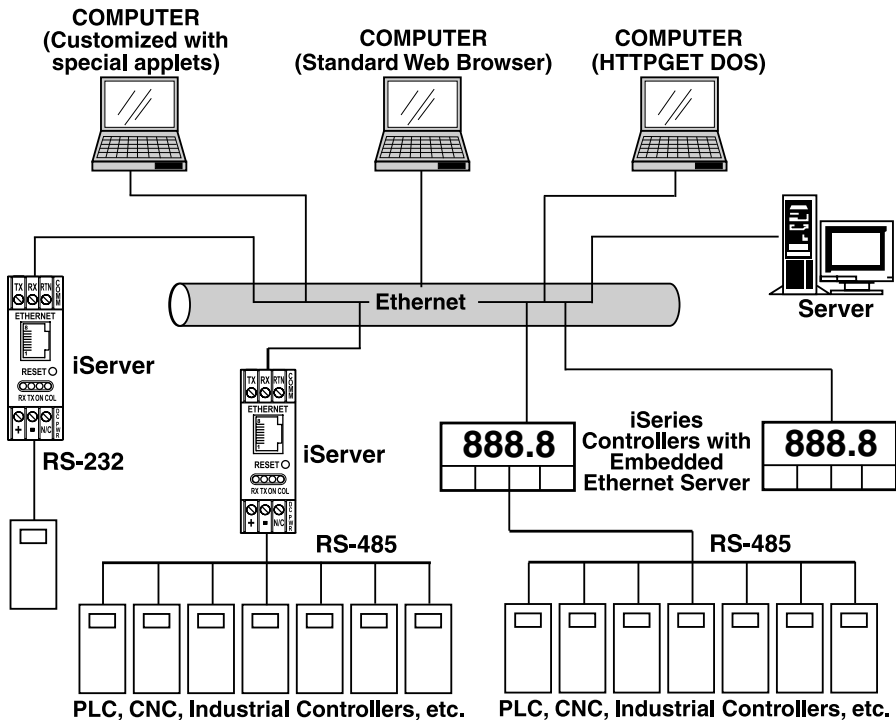

**Figure 1.1 Embedded Ethernet Server on the Ethernet Network**

## PART 2 HARDWARE

### 2.1 Physical Characteristics and Mounting

**Note** For physical dimensions and installation instructions see Quickstart and Manual for iSeries monitor/controller.

### 2.2 Rear Panel of iSeries Meter with Embedded Ethernet Server

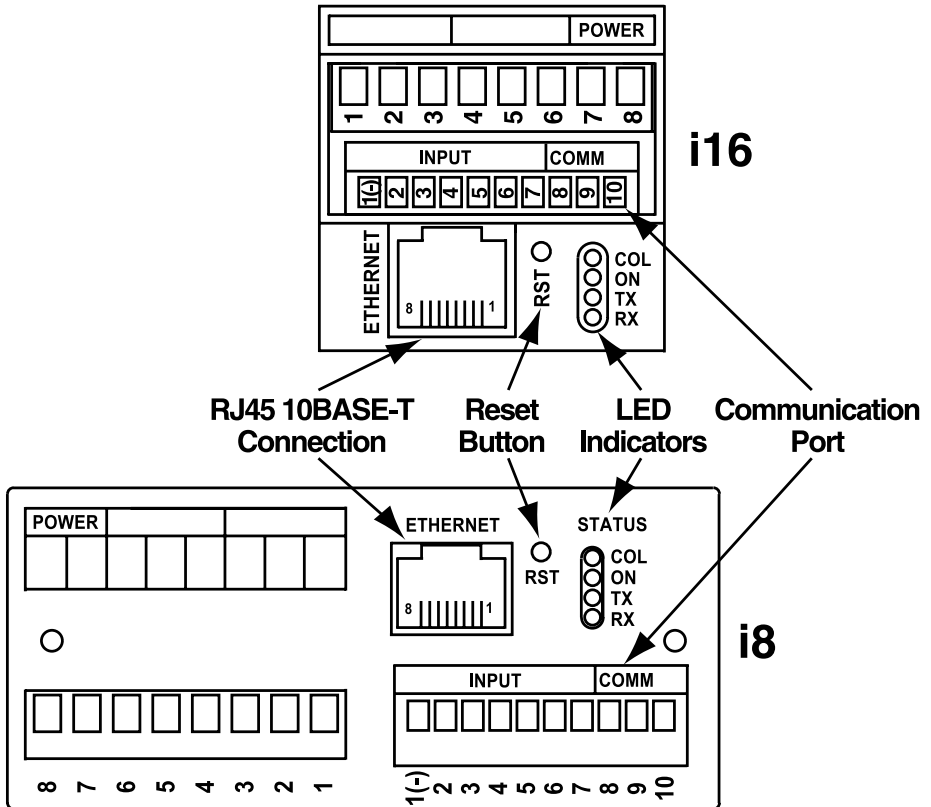

Figure 2.1 Rear Panel view of i16 and i8 Series Meters with Embedded Ethernet Server

**Table 2.1 Rear Panel Annunciators**

<b>Serial Communication Interface Section (For Models with RS485):</b>	
<b>Pin 10</b>	-Rx/-Tx
<b>Pin 9</b>	+Rx/+Tx
<b>Pin 8</b>	Return, Common Ground Shield Connection
<b>Network Communication Interface Section:</b>	
<b>Ethernet</b>	RJ45 Female Connector for 10BASE-T connection
<b>Reset</b>	Reset button used to change an IP Address and reset to the default password
<b>RX</b>	LED (Green) Flashing: Indicates transmission from the Serial port ON: Indicates that the reset button is momentarily pushed
<b>TX</b>	LED (Yellow) Flashing: Indicates reception to the Serial port ON: Indicates that the reset button is momentarily pushed
<b>ON</b>	LED (Green) ON: Indicates Power On. Flashing: Indicates connection to network host established
<b>COL</b>	LED (Red) ON: Indicates that the Ethernet communication collapsed due to high network traffic



**Both RX and TX stay ON when the reset button is pushed. They turn OFF after a new IP address has been entered.**

## 2.3 Serial Communication Interfaces (For Models with RS485 Port)

The iSeries controller/monitor with the Embedded Ethernet Server option board support only RS485/422 interfaces. These standards define the electrical characteristics of a communication network. The RS485 port of the Ethernet Server is fully compatible for use with RS422 instruments. The RS485 is an extended version of the RS422 communication standard which increases the allowable number of devices from 10 to 32 by improving the electrical characteristics.

- The **RS485** standard (**multi-point**) allows one or more devices (multi-dropped) to be connected to the Ethernet Server using a two-wire connection (half-duplex) +Rx/+Tx and -Rx/-Tx. Use of RS485 communications allows up to 32 devices to connect to the Web Server with cable length up to 4000 feet long.



Although the RS485 is commonly referred to as a "two wire" connection, the Web Server also provides a ground/return shield connection to use as a common connection for EMI noise protection.

Table 2.2 shows some characteristics of the RS485 communication interface.

**Table 2.2**

<b>Data Transmission Characteristics</b>	<b>RS485</b>
Transmission Mode	Differential
Electrical connections	2 wire
Drivers per line	32 drivers
Receivers per line	32 receiver
Maximum data rate	10M bits/s
Maximum cable length	4000 ft (1200 meters)

### 2.3.1 Wiring RS485 Interface

RS485 interface uses a two-wire communication system (one for transmitting and one for receiving) plus a common wire to connect to the shield of the cable. It is recommended to use a shielded cable with one twisted pair.

**Note** Use of twisted pair and shield will significantly improve noise immunity.

Figure 2.2 shows multi-point, half-duplex RS485 interface connections for the Ethernet Server.

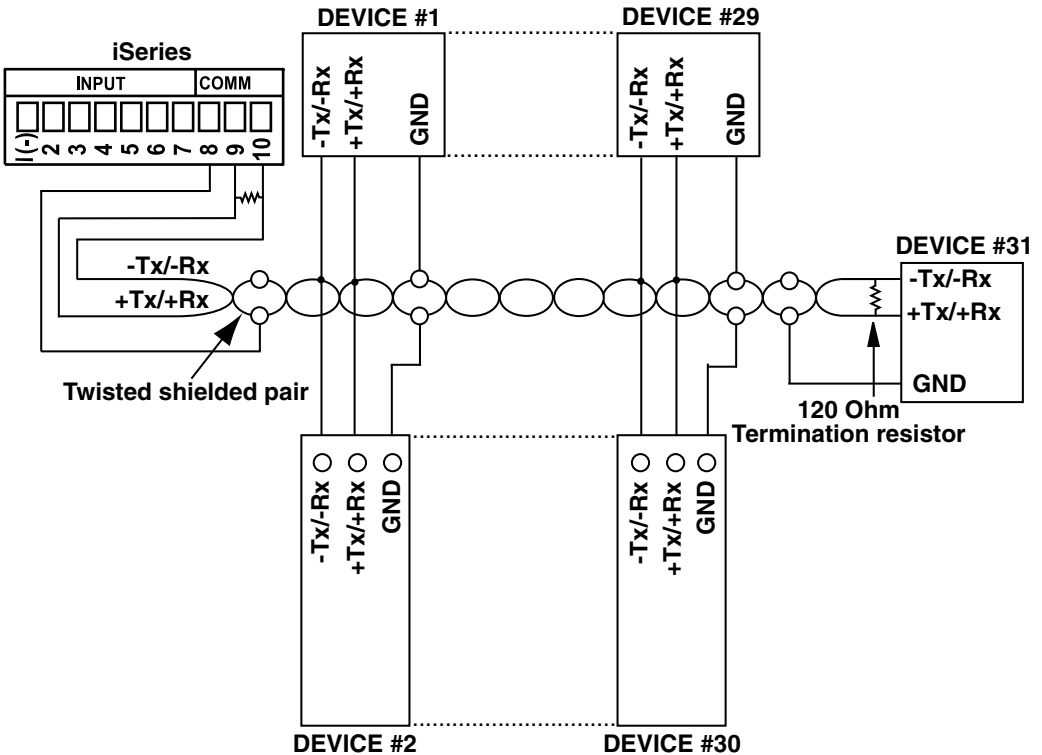

**Figure 2.2 Multi-point, Half-Duplex RS485 Wiring**

**Note** Value of the termination resistor is not critical and depends on the cable impedance.

Table 2.3 shows RS485 half-duplex hookup between the Ethernet Server serial port and device with RS485 communication interface.

**Table 2.3**

<b>iSeries</b>		<b>DEVICE # WITH RS485</b>
Pin 9	+Tx/+Rx (+Transmit/+Receive)	+Tx/+Rx (+Transmit/+Receive)
Pin 10	-Tx/-Rx (-Transmit/-Receive)	-Tx/-Rx (-Transmit/-Receive)
Pin 8	RTN (Common GND)	GND (Common GND)

## 2.4 Network Communication Interfaces

### 2.4.1 10Base-T RJ-45 pinout

The 10BASE-T Ethernet network (RJ-45) system is used in the Ethernet Server for network connectivity. The 10 Mbps twisted-pair Ethernet system operates over two pairs of wires. One pair is used for receiving data signals and the other pair is used for transmitting data signals. This means that four pins of the eight-pin connector are used.

#### ETHERNET

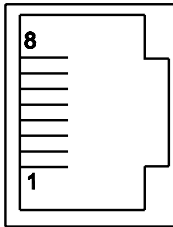

Pin	Name	Description
1	+Tx	+ Transmit Data
2	-Tx	- Transmit Data
3	+RX	+ Receive Data
4	N/C	Not Connected
5	N/C	Not Connected
6	-Rx	- Receive Data
7	N/C	Not Connected
8	N/C	Not Connected

Figure 2.3 RJ45 Pinout

### 2.4.2 10Base-T Crossover Wiring

When connecting the Ethernet Server directly to the computer, the transmit data pins of the computer should be wired to the receive data pins of the Ethernet Server, and vice versa. The 10Base-T crossover cable with pin connection assignments are shown on Figure 2.4.

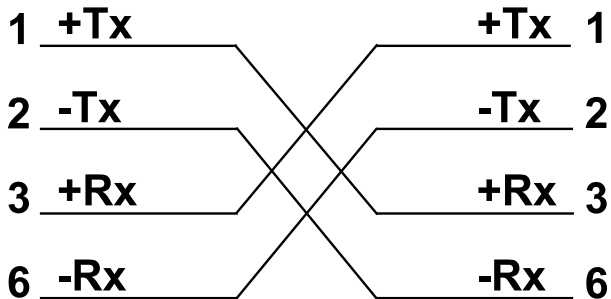

Figure 2.4 10Base-T Crossover Cable Wiring



Use straight through cable for connecting the Ethernet Server to the Ethernet network. Crossover will be done inside a hub.

## PART 3 NETWORK CONFIGURATION

### 3.1 Network Protocols

The Ethernet Server can be connected to the network using standard TCP/IP protocols. It is also supported by ARP and HTTP protocols. TCP/IP networking protocols are superimposed into a local Ethernet network until, if so desired, a connection is made to the Internet.

### 3.2 Ethernet (MAC) Address

MAC (Media Access Control) address is your computer's unique hardware number. When you're connected to the Internet from your computer, a correspondence table relates your IP address to your computer's physical (MAC) address on the LAN. The MAC address can be found on the label of your device and contains 6 byte (12 characters) of hexadecimal numbers XX:XX:XX:XX:XX:XX hex

For example: 0A:0C:3D:0B:0A:0B

You need to know this number to access the Ethernet Server to change the IP address.

**Note** There is room on the label to put your IP address. See Figures 3.1 and 3.2.

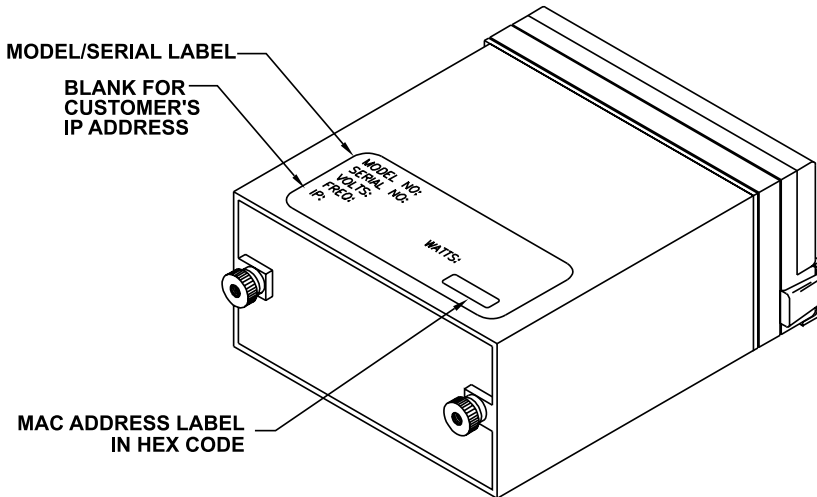

Figure 3.1 i8 - Labeling

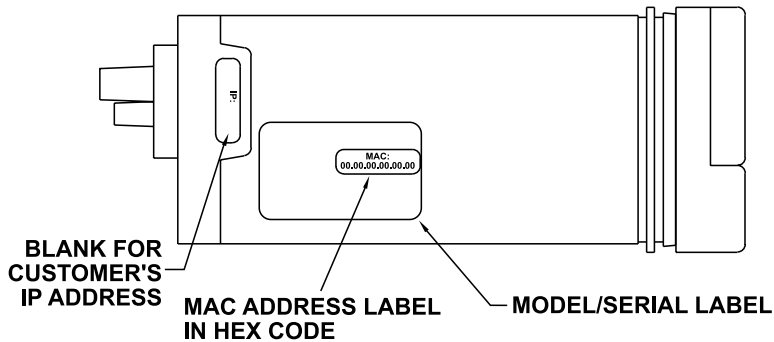

Figure 3.2 i16 - Labeling

### 3.3 IP Address

Every active device connected to the TCP/IP network must have a unique IP address. This IP address is used to build a connection to the Ethernet Server serial port. Every computer using TCP/IP should have a unique 32-bit address. It is divided into two portions, the network ID and the host ID. For instance, every computer on the same network uses the same network ID. At the same time, all of them have a different host ID. For more details about the IP address see Appendix B.

#### 3.3.1 Default IP Address

The Ethernet Server is shipped with a default IP address set to **128.100.101.254**. If you are going to use a Web browser or HTTPGET program to access the device, make sure that the default IP address is available to the instrument before processing. If the factory default address is already in use in your network, use the Ethernet crossover cable connected to one computer to access the device and modify the IP address from factory defaults.

### 3.4 Subnetting

Subnetting is the process of dividing a block of IP addresses assigned as a Class A, B, or C network into multiple, smaller blocks of addresses. After they are divided, you can use your network more efficiently. For more details about Subnetting see Appendix C (Subnet Masks).

### 3.5 Port Number

All TCP connections are defined by the IP address and a port number. A port number is an internal address that provides an interface between an application running on your computer and network through the TCP/IP protocol software. Some services or processes have conventionally assigned permanent port numbers.

There are two permanent TCP socket port numbers assigned to the Ethernet Server:

- A destination or well-known socket port number that is assigned to a specific application by IANA (Internet Assigned Numbers Authority). It serves as http port number: **80**
- Source socket port number: **1000**

## PART 4 SERIAL INTERFACE CONFIGURATION

An industrial device with serial interfaces (PLC, CNC controllers, PC, Data Display Devices, etc.) can be connected to the serial port of the Web Server.

### 4.1 Communication Protocol

A data communication protocol defines the rules and structure of messages used by all devices on a network for data exchange. A typical transaction will consist of a request to send from the MASTER followed by the response from one or more SLAVE devices. Either a single (point-to-point) or multi-drop network (multi-point) is possible.

### 4.2 Command Structure

There are different command types associated with communication between the Ethernet Server and your device shown in Table 4.1, which shows the Command Prefix Letters (Command Classes)

**Table 4.1 Command Prefix Letters**

COMMAND PREFIX (COMMAND CLASS)	MEANING
^AE	Special read, Communication parameters
P (Put)	Write HEX data into RAM
W (Write)	Write HEX data into EEPROM.
G (Get)	Read HEX data from RAM
R (Read)	Read HEX data from EEPROM
U	Read status byte
V	Read measurement data string in decimal format
X	Read measurement data values in decimal format
D	Disable
E	Enable
Z	Reset

### 4.3 Command Formats

Table 4.2 shows the command formats for the Ethernet Server.

**Table 4.2 Command Formats**

For "P" and "W" Command classes:	For "G" and "R" Command classes:	For "X", "V", "U", "D", "E", & "Z" Command classes:
<b>Point-to-point mode</b> * ccc<data><cr>	<b>Point-to-point mode</b> * ccc <cr>	<b>Point-to-point mode</b> * ccc <cr>
<b>Multi-point mode</b> * ncccc [<data>]<cr>	<b>Multi-point mode</b> * ncccc <cr>	<b>Multi-point mode</b> * ncccc <cr>

Where:

"\*" is the selected Recognition Character. You may select any ASCII table symbol from "!" (HEX address "21") to the right-hand brace (HEX "7D") except for the caret "^", "A", "E", which are reserved for bus format request.

"cc" stands for the hex-ASCII Command Class letter (one of eleven given in Table 4.1), followed by the two hex-ASCII Command Suffix characters identifying the meter data, features, or menu items to which the command is directed.

"<data>" is the string of characters containing the variable information the computer is sending to the meter. These data (whether BCD or binary) are encoded into hex-ASCII character (see Appendix D for binary-hex-ASCII chart), two characters to the byte. Square brackets [indicating optional status] enclose this string, since some commands contain no data.

"<nn>" are the two ASCII characters for the device Bus Address of RS485 communication. Use values from "00" to hex "C7" (199 decimal).

**The following format is used for each byte sent and received through serial port of Ethernet Server:**

1. Seven or Eight-bit binary, Hexadecimal (0 ... 9, A ... F)
2. Two hexadecimal characters contained in each eight-bit field of the message
3. 1 start bit; 7 or 8 data bit; 1 Stop Bit; Odd, Even (No Parity) Bit

The figure below shows the bit sequences when a byte is transmitted or received through the Ethernet Server.

LSB							MSB			
START	1	2	3	4	5	6	7	8	STOP	PARITY

LSB – Least Significant bit

MSB – Most Significant bit

Least Significant beat sent first

## PART 5 OPERATIONS

### 5.1 Modifying the IP Address

The IP Address may be set via the network by using "Setip" DOS program.

The setip.exe file is used to set a new IP Address. This file will be automatically installed when you run any Ethernet Server related software available on our website and CD.

Example to use the "setip" program:

1. Choose a qualified new IP address.
2. Make sure that the new IP address is available to the device before processing by pinging the new IP address:



"Ping.exe" file should be installed and available on each computer configured to use TCP/IP.

#### C:\ping 128.100.101.33

If you get the following response, it means that this IP address is not taken:

Pinging 128.100.101.33 with 32 bytes of data.

Request timed out:  
Request timed out:  
Request timed out:  
Request timed out:

3. Create a directory C:\WebServer\Setip
4. Copy setip.exe file to this directory.



Push the "**Reset**" button on the Ethernet Server before proceeding to the next step.

5. Make sure that you are on this directory and then enter "setip", followed by the MAC address and the new IP address:

C:\WebServer\Setip\setip XX:XX:XX:XX:XX:XX DDD.DDD.DDD.DDD

or

C:\WebServer\Setip\setip ddd.ddd.ddd.ddd.ddd.ddd DDD.DDD.DDD.DDD

where: XX:XX:XX:XX:XX:XX is a MAC address in hexadecimal  
ddd.ddd.ddd.ddd.ddd.ddd is a MAC address in decimal  
DDD.DDD.DDD.DDD is a new IP address in decimal

**For example:**

**C:\WebServer\Setip\setip 0A:0C:3D:0B:0A:0B 128.100.101.33 for MAC address in Hexadecimal**

**C:\WebServer\Setip\setip 10.12.61.11.10.11 128.100.101.33 for MAC address in decimal**

6. Make sure that the Ethernet Server has a new IP address by pinging the new IP address

**C:\ping 128.100.101.33**

If you got the following respond, it means that your device now has the new IP address:

Pinging 128.100.101.33 with 32 bytes of data.

Reply from 128.100.101.33: bytes = 32 time = 4 ms TTL = 32

Reply from 128.100.101.33: bytes = 32 time = 4 ms TTL = 32

Reply from 128.100.101.33: bytes = 32 time = 4 ms TTL = 32

Reply from 128.100.101.33: bytes = 32 time = 4 ms TTL = 32

## 5.2 HTTPGET Program

You can setup and read the information from the Ethernet Server by using the HTTPGET program. The following program can be used to read data from the embedded server firmware by using TCP port 1000. The command string sends to this TCP port, then it reads back the response from the same port. Whatever you write to the port goes to the serial port unmodified. Any response from the serial port can be read back from the same socket.

The Httpget.exe file is used to setup and read information from the Ethernet Server. This file will be automatically installed when you run any Web Server related software available on our website and CD.

Example to use the "**Httpget**" program:

1. Create a directory **C:\WebServer\Httpget**.
2. Copy httpget.exe and readme\_features.doc files to this directory.
3. Make sure that you are in this directory and then enter the following test program:

```
C:\WebServer\Httpget\httpget -r -S "*01X01\r" 128.100.101.254:1000
```

where:

"-r -S" are switches before the command string

"01" is device address (in Hex Format) for RS485 communication interface (skip for RS232)

"X01" read measurement data value (iSeries protocol)

"\r" calls out a CR

"128.100.101.254" is an IP address

"1000" is a socket port number

Respond:

```
01X01074.3
```

where:

"01X01" is Echo command

"074.3" is a display reading of the 4-digit device

**Note**

In the example above the 4-digit iSeries controller has been connected to the serial communication port of Ethernet Server.

### 5.3 ARP Protocol

ARP is the Internet layer protocol responsible for determining the MAC (hardware) address that corresponds to a particular IP address. The ARP command allows the user to view the current contents of the ARP cache of the local computer (residing on the same network) or remote computer (residing on the different network) through a router. Microsoft includes the ARP.EXE utility for viewing and modifying the ARP cache with its Windows product. The following ARP commands can be used to view cache entries:

- **arp -a** → Use this command to view all ARP cache entries.
- **arp -a** plus **IP address** → Use this command to view ARP cache entries associated with one particular interface on a network with multiple adapters.
- **arp -g** → Same as arp -a.
- **arp -N** → Use this command to display ARP entries for specific network interface.
- **arp -s** plus **IP address** plus **Physical address** → Use this command to manually add a permanent static entry to the ARP cache.
- **arp -d** → Use this command to manually delete a static entry.



Ping the destination computer using IP address first before using the arp -a command.

Figure 5.1 below shows examples of arp commands and responses. Your computer has an IP address 128.100.101.118. The destination computer has an IP address 128.100.101.96

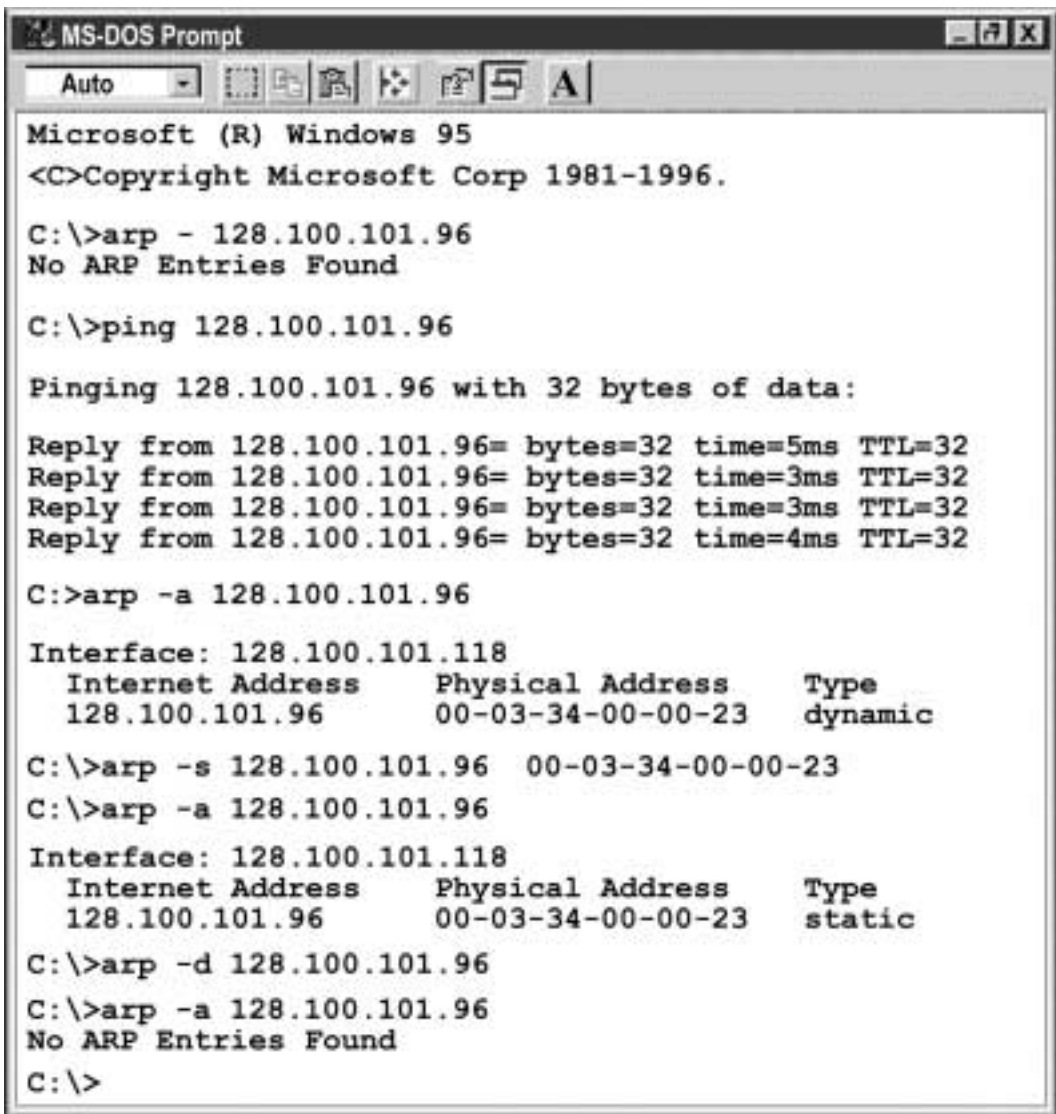

```
MS-DOS Prompt
Auto
Microsoft (R) Windows 95
<C>Copyright Microsoft Corp 1981-1996.

C:\>arp - 128.100.101.96
No ARP Entries Found

C:\>ping 128.100.101.96

Pinging 128.100.101.96 with 32 bytes of data:

Reply from 128.100.101.96= bytes=32 time=5ms TTL=32
Reply from 128.100.101.96= bytes=32 time=3ms TTL=32
Reply from 128.100.101.96= bytes=32 time=3ms TTL=32
Reply from 128.100.101.96= bytes=32 time=4ms TTL=32

C:\>arp -a 128.100.101.96

Interface: 128.100.101.118
  Internet Address      Physical Address      Type
  128.100.101.96       00-03-34-00-00-23    dynamic

C:\>arp -s 128.100.101.96 00-03-34-00-00-23
C:\>arp -a 128.100.101.96

Interface: 128.100.101.118
  Internet Address      Physical Address      Type
  128.100.101.96       00-03-34-00-00-23    static

C:\>arp -d 128.100.101.96
C:\>arp -a 128.100.101.96
No ARP Entries Found
C:\>
```

Figure 5.1 arp -a Commands and Responses

## 5.4 Setup and Operation using the iServer Web Page

**Note**

This home page is designed for our company product using iSeries serial communication protocol. It can be utilized for other products using the standard RS232/485 communication interface.

1. Start your Web browser (Internet Explorer 5.0 or Netscape Navigator 6.0).
2. From a File menu select "Open" or "Open Web Location".
3. Enter the Internet address (IP address of your device on the network)
4. The home page of the iServer shown below will be displayed in your browser.



**Figure 5.2 iServer Home Page**

**Note**

In order to be able to access certain menu items of the home page, users may be prompted to enter a password number. For more details see Chapter 5.4.5 "Configure Access Control".

This home page provides the following features:

### 5.4.1 Read Devices:

- Read variables from up to four different devices.

**READ DEVICES**

**081.6 F**

<u>1.</u>	Temp	081.6	F
<u>2.</u>	Strain	009.0	psi
<u>3.</u>	Process Voltage	041.1	mV
<u>4.</u>	Process Current	016.4	mA

- Read up to four variables from the same device.
- Manually or automatically update readings from your devices. Set time interval for Auto Update.

**READ DEVICES**

**081.5 F**

<u>1.</u>	Current Process Value	081.5	F
<u>2.</u>	Peak Value	081.5	F
<u>3.</u>	Valley Value	077.9	F
<u>4.</u>	SW Version	1.1	

- Read and write the setpoint values to the device.

**DEVICE SETPOINTS**

Device No. 1 (\*01)

Temperature value Setpoint #1:

Temperature value Setpoint #2:

Note

If access to the menu item is restricted (untrusted host), the user will be prompted for a password number. In order to proceed to the "Device Setpoints" submenu, the user should enter the correct password for access level "1" (operator level) or access level "0" (administrator level).



**i DEVICE SETPOINTS**  
Missing or invalid password!  
Password:

#### 5.4.2 Send Raw Command

- Send single command and receive response.

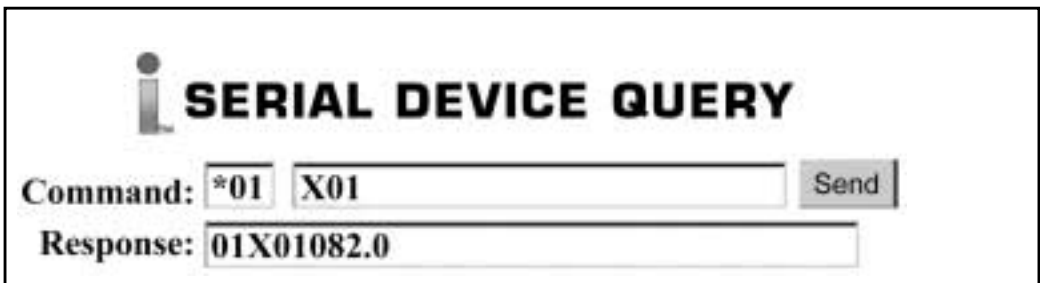

**i SERIAL DEVICE QUERY**  
Command:    
Response:

#### 5.4.3 Modify Device List Entry

- Modify device list or parameters.

Note

Device Address or ID is in Hex Format. See **Appendix D** for conversion.

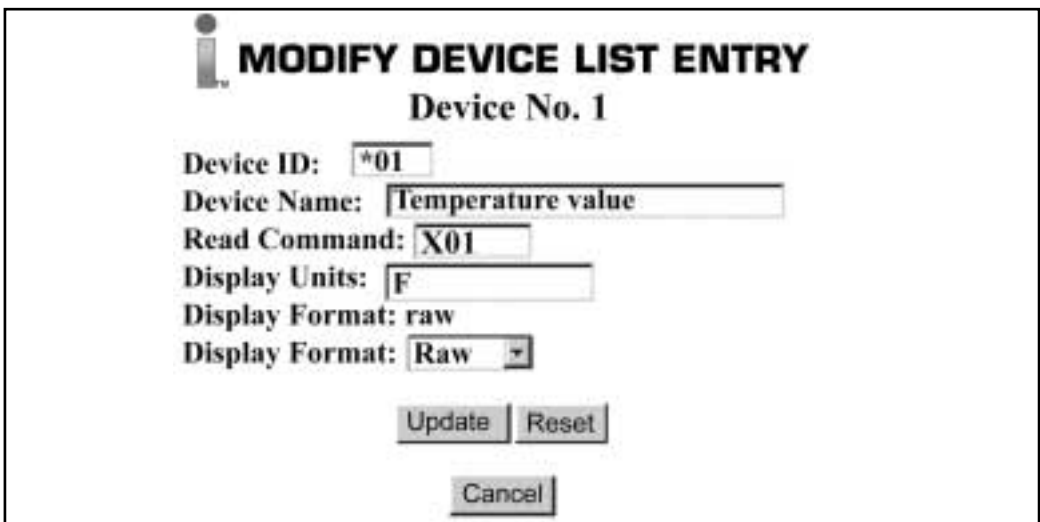

**i MODIFY DEVICE LIST ENTRY**  
Device No. 1  
Device ID:   
Device Name:   
Read Command:   
Display Units:   
Display Format: raw  
Display Format:

- Up to four different devices or parameters can be modified.



## DEVICE SETUP

No.	Device Name	Device ID	Read Command	Display Units	Display Format
<u>1</u>	Temp	*01	X01	F	raw
<u>2</u>	Strain	*02	X01	psi	raw
<u>3</u>	Process Voltage	*03	X01	mV	raw
<u>4</u>	Process Current	*04	X01	mA	raw

#### 5.4.4 Serial Port Configuration

- Allows the user to adjust serial communications settings of the instrument.
- When connecting your instrument to the iServer, the communications parameters must match.



## SERIAL PORT CONFIGURATION

Speed:  2400  4800  9600  19200  38400  57600  115200 baud

Bad parity:  dropped  accepted  marked (MSB set)

Parity:  none  even  odd

Transceiver:  RS-232  RS-485

Timeout:  msec

### 5.4.5 Configure Access Control

- Allows the network administrator to set a different access level to the iServer parameters for the different groups or individual users.

**i CONFIGURE ACCESS CONTROL**

**This is an untrusted host**

Trusted Hosts									
No.	IP Address			Netmask			Access Level*		
1	128.100.101.143	255.255.255.255	255.255.255.255	0					
2	128.100.101.120	255.255.255.255	255.255.255.255	0					
3	255.255.255.255	255.255.255.255	255.255.255.255	0					
4	255.255.255.255	255.255.255.255	255.255.255.255	0					
<input type="checkbox"/>	<input type="checkbox"/>	<input type="checkbox"/>	<input type="checkbox"/>	<input type="checkbox"/>	<input type="checkbox"/>	<input type="checkbox"/>	<input type="checkbox"/>	<input type="checkbox"/>	<input type="checkbox"/>

\*0=all 1=operator 2=read-only

New Level 0 Password:

New Level 1 Password:

There are three different access levels:

1. Access Level "0" (administrator level) allows certain groups and individual users to access and modify "All" iServer menu items without any restrictions (Trusted Host).
2. Access Level "1" (operator level) allows certain groups and individual users to access and modify "Read Devices" and "Device Setpoints" menus only (Untrusted Host).
3. Access Level "2" (read-only level) allow certain groups and individual users to access "Read Devices" menu only (Untrusted Host)

The network administrator can change the access level by properly masking certain IP addresses. See Appendix C for more details about the IP Netmask.

### 5.4.6 Log In

- Allows the user to access the menu items of the iServer Home page according to their access level. Except for "Read Device", if user attempts to advance to the menu items, they will be prompted to enter the password only once to open the menu items.



**i LOGIN**  
This is an untrusted host  
Password: [\*\*\*\*\*] [Login]

### 5.4.7 Change ID

- Allows the user to access devices with different addresses residing on RS485 communication interface.



[Change ID] [\*01]



ID number relates to the Device or Variable No. Refer to Device Setup **Section 5.4.3.**

ID number is blank for RS232 communication interface.



[Change ID] [\*]

## 5.5 Mail Notifier Software



For complete information of how to use the Mail Notifier software, click on the Help menu of the main window.

The Mail Notifier software utilizes E-Mail notifications of alarm conditions of the devices having either embedded iServer board or connected via the stand alone iServer units, which reformats RS232/485 bus traffic into Ethernet packets. Hence users/operators can be notified automatically of alarm conditions monitored via internet connections throughout the world. By use of the E-Mail forwarding of alarm conditions, alarm conditions can be monitored on a network isolated from the internet and forwarded to connections on the Internet.

The Mail Notifier utility operates under Windows 95,98, NT 4.0, and NT 2000 in conjunction with existing E-Mail that supports the MAPI messaging interface. If MS Outlook has been loaded, the MAPI support should be available.

### 5.5.1 Installation

The Mail Notifier must be loaded on a computer running Microsoft Windows (versions specified earlier) and with a MAPI client software. Network access must be available between this computer and the iServer. Network access must also be available from this computer to the appropriate E-Mail server and from the E-Mail server to the recipient's E-Mail server.



Figure 5.3 iServer Mail Notifier Main Window

## 5.5.2 Program Options Setup and Configuration

Complete program setup requires:

- Entering a recipient for the E-Mail
- Specifying connection details to MAPI services.
- Defining alarms for devices, and selecting how and when the E-Mail will be active.



**Figure 5.4 iServer Mail Notifier Profile Setup**

The E-Mail User tab provides fields to define the name/profile for the Mail Notifier to utilize when E-Mail is sent.

Follow the steps below to set profile in Microsoft Exchange (5.0.1458.47)

1. Start Microsoft Exchange.
2. From Menu bar select tools, options.
3. It will open to the General tab.
4. On the General tab there is the "When starting Microsoft Exchange" options.
5. The profile name is specified under the "Always use this profile" option button.
6. On the Mail Notifier, go to View, Options.
7. From the options dialog, go to the E-mail User tab.
8. Set the Name/Profile to the profile name obtained in step 5
9. Make sure that the E-Mail Access option is set to MS Outlook. (This is used to prevent input of a password -- which isn't going to be used with Microsoft Exchange)

The Send To tab contains a field to specify an E-mail address to which alarm notifications will be sent. Only one entry is permitted, but with some E-Mail packages, the entry can represent a group of users with different E-Mail addresses.

### 5.5.3 Device Setting Setup and Configuration

Device setup requires:

- Entering the IP address for iServer device (for example 128.100.101.98).
- Specifying Socket number (1000 for iServer).
- Defining RS485 Unit # serial interface address (1 to 199). Enter "0" for RS232 interface.
- Entering Reading command. Normally set to X01 to obtain reading from the devices.
- Defining the Alarm setup (High/Low, High value, or Low value).
- Specifying Pause Interval. It determines how many seconds each subsequent alarm notification will be sent.
- Determining Monitor interval. It establishes the interval or time resolution in seconds for which readings will be obtained from the device.

The screenshot shows a dialog box titled "Alarm Editor" with a close button (X) in the top right corner. The dialog is divided into two main sections: "device info (2 of 2)" and "Alarm Configuration".

**device info (2 of 2)**

Server IP Address	128.100.101.98
Socket Number	1000
RS485 Unit #	1
Description	iSeries Controller
Src ID	Dev 2
Reading Cmd	X01

On the right side of the "device info" section, there are five buttons: "OK", "Cancel", "Help", "Add", and "Del".

**Alarm Configuration**

Alarm Type	Alarm Low	Info Message	Alarm triggered
Alarm High	70	Pause Interval	60
Alarm Low	100	Monitor Interval	5

Figure 5.5 iServer Mail Notifier Device Setting

## **PART 6 SPECIFICATIONS**

### **Standards Compliance**

IEEE 802.3 10Base-T

### **Supported Protocols**

TCP/IP, ARP, HTTPGET

### **Serial Interface (if applicable)**

Communication Standard: RS485, RS422

Transfer speed (Baud rate): 2400, 4800, 9600, 19200, 38400, 57600, 115200 bps

Bad Parity: dropped, accepted, marked

Parity bit: odd, even, none

Data bit: 7, 8 bit

Stop bit: 1 bit

Start bit: 1 bit

Multi-point Address (RS485): 0 to 199

Flow Control: No Flow control

Screw terminals for RS232/485/422 interface

### **Network Interface**

10Base-T port (RJ45 connector)

Socket Port number: 1000

HTTP Port number: 80

### **Power**

10 to 32 Vdc

### **Power Consumption**

2 W

### **Environmental Conditions**

0 to 50°C (32 to 122°F), 90% RH

 Refer to the iSeries Manual and Quickstart for physical characteristics of iSeries devices with the Embedded Ethernet Server.

### **Approvals**

UL, CUL and see CE Approval Section

**PART 7**  
**FACTORY PRESET VALUES**

<b>PRESET PARAMETERS</b>	<b>FACTORY DEFAULTS</b>	<b>NOTES</b>
<b>Network Interface:</b>		
IP address	128.100.101.254	
<b>Serial Interface:</b>		
Communication Standard	RS485	
Transfer Speed	9600 bps	
Bad Parity	accepted	
Parity	odd	
Timeout	750 msec	

# CE APPROVAL INFORMATION

## 1. Electrical Compatibility (EMC)

**This device conforms with requirements of EMC Directive 89/336/EEC, amended by 93/68/EEC. This instrument complies with the following EMC Immunity Standards as tested per EN 50082-2, 1995 (Industrial environment)**

Phenomena	Test Specification	Basic Standard
Electrostatic Discharge	+/- 4 kV contact discharge +/- 8 kV air discharge	IEC 1000-4-2 Performance Criteria B
Radio Frequency electromagnetic field.	27 - 1000 MHz 10 V/m 80% AM (1 KHz)	IEC 1000-4-3 Performance Criteria A
Radio Frequency electromagnetic field. Pulse modulated.	900 MHz 10 V/m 50% Duty cycle @ 200 Hz	IEC 1000-4-3 Performance Criteria A
Fast Transients	+/- 2 kV (ac mains) +/- 1 kV (dc, signal I/O) 5/50 ns Tr/Th, 5 KHz rep. freq.	IEC 1000-4-4 Performance Criteria B
Radio Frequency conducted	0.15 - 80 MHz 10 V/m 80% AM (1 KHz)	IEC 1000-4-6 Performance Criteria A

**This instrument complies with the following EMC Emission Standards as tested per EN 50081-1, 1992 (Residential, Commercial and Light Industrial)**

Phenomena	Frequency Range	Limits	Basic Standard
Radiated Emission	30-230 MHz 230-1000 MHz	30 dB_V/m at 10 m 37 dB_V/m at 10 m quasi peak	CISPR 22 Class B
Conducted Emission	0.15-0.5 MHz 0.5-5 MHz 5-30 MHz	66-56 dB_V quasi peak 56 dB_V quasi peak 60 dB_V quasi peak	CISPR 22 Class B

## 2. Safety

**This device conforms with Low Voltage Directive 73/23/EEC, amended by 93/68/EEC. The following LVD requirements have been met to comply with EN 61010-1, 1993 (Electrical equipment for measurement, control and laboratory use)**

1. Pollution Degree 2
2. Installation Category II
3. Double Insulation
4. Class II Equipment (90-240 Vac Powered Units)  
Class III Equipment (12-36 Vdc Low Power Option)

## FCC

This device complies with Part 15, Subpart B, Class B of the FCC rules

User of this manual should be familiar with following definitions:

**ARP (Address Resolution Protocol)** is a protocol for mapping an Internet Protocol address (IP address) to a physical machine address that is recognized in the local network. For example, the IP address in use today is an address that is 32-bits long. In an Ethernet local area network, however, addresses for attached devices are 48-bits long. (The physical machine address is also known as a Media Access Control or MAC address.) A table, usually called the ARP cache, is used to maintain a correlation between each MAC address and its corresponding IP address. ARP provides the protocol rules for making this correlation and providing address conversion in both directions.

**Ethernet** is a network protocol defined by the IEEE 802.3 standard. Ethernet-based networks use MAC Address rather than IP Address to exchange data between computers. By using ARP and adding TCP/IP support, Ethernet devices may be connected as part of the Internet. An Ethernet LAN typically uses coaxial cable or special grades of twisted pair wires. The most commonly installed Ethernet systems are called 10BASE-T and provide transmission speeds up to 10 Mbps. Devices are connected to the cable and compete for access using a Carrier Sense Multiple Access with Collision Detection (CSMA/CD) protocol.

**IP (Internet Protocol)** is the method or protocol by which data is sent from one computer to another on the Internet.

**IP address (Internet Protocol address)** is a 32-bit number that identifies each sender or receiver of information that is sent in packets across the Internet.

**IP Netmask** is a 32-bit pattern of bits used to determine which part of the IP address is the network portion and which part is the host portion.

**MAC (Media Access Control) Address** is your computer's unique hardware number. When you're connected to the Internet from your computer, a correspondence table relates your IP address to your computer's physical (MAC) address on the LAN.

**Ping** is a utility that tests the network connectivity. It is used to determine if the host is capable of exchanging information with another host.

**Port number/Socket number** is a way to identify a specific process to which an Internet or other network message is to be forwarded when it arrives at a server. It is a predefined address that serves as a route from the application to the Transport layer or from the Transport layer to the application of the TCP/IP system.

**Sockets** are a method for communication between a client program and a server program in a network and defined as "the endpoint in a connection." Information transferred across the Internet primarily occurs between sockets.

**TCP/IP (Transmission Control Protocol/Internet Protocol)** is the basic communication language or protocol of the Internet. When you are set up with direct access to the Internet, your computer is provided with a copy of the TCP/IP program just as every other computer that you may send messages to or get information from also has a copy of TCP/IP. TCP/IP often is used as a general term to indicate generic access to the Internet.

## Appendix B

## IP Address

An IP address is a unique 32-bit address assigned to a computer and includes:

- A network ID number identifying a network.
- A host ID number identifying a computer on the network.

All IP addresses have been divided into three smaller groups (classes) A, B and C

- **Class A** addresses have 8-bits of network ID and 24-bits of host ID. They can support a large number of hosts, approximately  $2^{24} = 16,777,216$  computers per network.

The IP addresses range in binary from 00000001.xxxxxxxx.xxxxxxxx.xxxxxxxx  
to 01111111.xxxxxxxx.xxxxxxxx.xxxxxxxx

The IP addresses range in decimal from 1.x.x.x to 127.x.x.x

Class A network ID's support a very large number of hosts.

- **Class B** addresses have 16-bits of network ID and 16-bits of host ID. They can support approximately  $2^{16} = 65,536$  computers per network.

The IP addresses range in binary from 10000000 00000000.xxxxxxxx.xxxxxxxx  
to 10111111 11111111.xxxxxxxx.xxxxxxxx

The IP addresses range in decimal from 128.0.x.x TO 191.255.xxx.xxx

Class B network ID's support a medium number of hosts.

- **Class C** addresses have 24-bits of network ID and 8-bits of host ID. They can support approximately  $2^8 = 256$  computers per network.

The IP addresses range in binary from 11000000.00000000.00000000.xxxxxxxx  
to 11011111.11111111.11111111.xxxxxxxx

The IP addresses range in decimal from 192.0.0.xxx to 223.255.255.xxx

Class C network ID's support a small number of hosts.

The rest of the addresses are divided into two classes, D and E.

**Note**

**Class D networks** are not assigned to the host. They are used for multicasting. The address range from 224.x.x.x to 239.x.x.x

**Class E** networks are experimental or reserved addresses. The address range from 240.x.x.x to 247.x.x.x

## Appendix C

## IP Netmask

IP Netmask or Subnet Mask is a 32-bit pattern of ones and zeros used to determine network portion of an IP address from the host portion of the IP address. Subnet mask is a network ID that is created by borrowing bits from host portion of IP address and using them as part of a network ID. The table below shows a default subnet mask for address Classes A, B, and C. Each bit that is set to "1" in the subnet mask corresponds to the bit in the IP address that is to be used as the network ID. Each bit that is set to "0" in the subnet mask corresponds to a bit in the IP address that is to be used as the host ID.

Address Class	Mask Binary Value	Mask Decimal Value or Dotted Notation
Class A	11111111 00000000 00000000 00000000	255.0.0.0
Class B	11111111 11111111 00000000 00000000	255.255.0.0
Class C	11111111 11111111 11111111 00000000	255.255.255.0

If your network requires more network ID's, you can extend the default subnet mask to include additional bits from the host ID. This allows for additional network ID's within the network. The table below shows some examples of subnet masks and bits moved from the hosts ID to create a new subnet.

Mask Dotted Notation	Mask Binary	Mask Bits
<b>Class A</b>		
255.0.0.0 (Default)	11111111 00000000 00000000 00000000	0
255.192.0.0	11111111 11000000 00000000 00000000	2
255.224.0.0	11111111 11100000 00000000 00000000	3
255.240.0.0	11111111 11110000 00000000 00000000	4
255.248.0.0	11111111 11111000 00000000 00000000	5
255.252.0.0	11111111 11111100 00000000 00000000	6
255.254.0.0	11111111 11111110 00000000 00000000	7
255.255.0.0	11111111 11111111 00000000 00000000	8
255.255.128.0	11111111 11111111 10000000 00000000	9
255.255.192.0.0	11111111 11111111 11000000 00000000	10
.....	.....	.
255.255.255.252	11111111 11111111 11111111 11111100	22
<b>Class B</b>		
255.255.0.0 (Default)	11111111 11111111 00000000 00000000	0
255.255.192.0	11111111 11111111 11000000 00000000	2
.....	.....	.
255.255.255.252	11111111 11111111 11111111 11111100	14
<b>Class C</b>		
255.255.255.0 (Default)	11111111 11111111 11111111 00000000	0
255.255.255.192	11111111 11111111 11111111 11000000	2
.....	.....	.
255.255.255.254	11111111 11111111 11111111 11111100	6

To determine the number of valid hosts ID's remaining after subnetting, use the following equation:  $2^n - 2$ , where n is the number of octet digits left after the subnet mask.

Appendix D

ASCII Chart

ASCII Char	Dec	Hex	Binary No Parity	ASCII Char	Dec	Hex	Binary No parity
NUL	00	00	00000000	@	64	40	01000000
SOH	01	01	00000001	A	65	41	01000000
STX	02	02	00000010	B	66	42	01000010
ETX	03	03	00000011	C	67	43	01000011
EOT	04	04	00000100	D	68	44	01000100
ENQ	05	05	00000101	E	69	45	01000101
ACK	06	06	00000110	F	70	46	01000110
BEL	07	07	00000111	G	71	47	01000111
BS	08	08	00001000	H	72	48	01001000
HT	09	09	00001001	I	73	49	01001001
LF	10	0A	00001010	J	74	4A	01001010
VT	11	0B	00001011	K	75	4B	01001011
FF	12	0C	00001100	L	76	4C	01001100
CR	13	0D	00001101	M	77	4D	01001101
SO	14	0E	00001110	N	78	4E	01001110
SI	15	0F	00001111	O	79	4F	01001111
DLE	16	10	00010000	P	80	50	01010000
DC1	17	11	00010001	Q	81	51	01010001
DC2	18	12	00010010	R	82	52	01010010
DC3	19	13	00010011	S	83	53	01010011
DC4	20	14	00010100	T	84	54	01010100
NAK	21	15	00010101	U	85	55	01010101
SYN	22	16	00010110	V	86	56	01010110
ETB	23	17	00010111	W	87	57	01010111
CAN	24	18	00011000	X	88	58	01011000
EM	25	19	00011001	Y	89	59	01011001
SUB	26	1A	00011010	Z	90	5A	01011010
ESC	27	1B	00011011	[	91	5B	01011011
FS	28	1C	00011100	\	92	5C	01011100
GS	29	1D	00011101	]	93	5D	01011101
RS	30	1E	00011110	^	94	5E	01011110
US	31	1F	00011111	_	95	5F	01011111
SP	32	20	00100000	`	96	60	01100000
!	33	21	00100001	a	97	61	01100001
"	34	22	00100010	b	98	62	01100010
#	35	23	00100011	c	99	63	01100011
\$	36	24	00100100	d	100	64	01100100
%	37	25	00100101	e	101	65	01100101
&	38	26	00100110	f	102	66	01100110
'	39	27	00100111	g	103	67	01100111
(	40	28	00101000	h	104	68	01101000
)	41	29	00101001	i	105	69	01101001
*	42	2A	00101010	j	106	6A	01101010
+	43	2B	00101011	k	107	6B	01101011
,	44	2C	00101100	l	108	6C	01101100
-	45	2D	00101101	m	109	6D	01101101
.	46	2E	00101110	n	110	6E	01101110

**Appendix D**

**ASCII Chart Continuation**

/	47	2F	00101111	o	111	6F	01101111
0	48	30	00110000	p	112	70	01110000
1	49	31	00110001	q	113	71	01110001
2	50	32	00110010	r	114	72	01110010
3	51	33	00110011	s	115	73	01110011
4	52	34	00110100	t	116	74	01110100
5	53	35	00110101	u	117	75	01110101
6	54	36	00110110	v	118	76	01110110
7	55	37	00110111	w	119	77	01110111
8	56	38	00111000	x	120	78	01111000
9	57	39	00111001	y	121	79	01111001
:	58	3A	00111010	z	122	7A	01111010
;	59	3B	00111011	{	123	7B	01111011
<	60	3C	00111100		124	7C	01111100
=	61	3D	00111101	}	125	7D	01111101
>	62	3E	00111110	~	126	7E	01111110
?	63	3F	00111111	DEL	127	7F	01111111

**ASCII Control Codes**

ASCII Char	Dec	Hex	Ctrl Key Equiv.	Definition	ASCII Char	Dec	Hex	Ctrl Key Equiv.	Definition
NUL	00	00	Ctrl @	Null Character	DC1	17	11	Ctrl Q	Data Control 1 - XON
SOH	01	01	Ctrl A	Start of Header	DC2	18	12	Ctrl R	Data Control 2
STX	02	02	Ctrl B	Start of Text	DC3	19	13	Ctrl S	Data Control 3 - XOFF
ETX	03	03	Ctrl C	End of Text	DC4	20	14	Ctrl T	Data Control 4
EOT	04	04	Ctrl D	End of Transmission	NAK	21	15	Ctrl U	Negative Acknowledge
ENQ	05	05	Ctrl E	Inquiry	SYN	22	16	Ctrl V	Synchronous Idle
ACK	06	06	Ctrl F	Acknowledge	ETB	23	17	Ctrl W	End of Trans Block
BEL	07	07	Ctrl G	Bell	CAN	24	18	Ctrl X	Cancel
BS	08	08	Ctrl H	Back Space	EM	25	19	Ctrl Y	End of Medium
HT	09	09	Ctrl I	Horizontal Tabulation	SUB	26	1A	Ctrl Z	Substitute
LF	10	0A	Ctrl J	Line Feed	ESC	27	1B	Ctrl [	Escape
VT	11	0B	Ctrl K	Vertical Tabulation	FS	28	1C	Ctrl \	File Separator
FF	12	0C	Ctrl L	Form Feed	GS	29	1D	Ctrl ]	Group Separator
CR	13	0D	Ctrl M	Carriage Return	RS	30	1E	Ctrl	Record Separator
SO	14	0E	Ctrl N	Shift Out	US	31	1F	Ctrl _	Unit Separator
SI	15	0F	Ctrl O	Shift In	SP	32	20		Space
DLE	16	10	Ctrl P	Data Link Escape					







## Warranty/Disclaimer

NEWPORT Electronics, Inc. warrants this unit to be free of defects in materials and workmanship for a period of **one (1) year** from the date of purchase. In addition to NEWPORT's standard warranty period, NEWPORT Electronics will extend the warranty period for **four (4) additional years** if the warranty card enclosed with each instrument is returned to NEWPORT.

If the unit should malfunction, it must be returned to the factory for evaluation. NEWPORT's Customer Service Department will issue an Authorized Return (AR) number immediately upon phone or written request. Upon examination by NEWPORT, if the unit is found to be defective it will be repaired or replaced at no charge. NEWPORT's WARRANTY does not apply to defects resulting from any action of the purchaser, including but not limited to mishandling, improper interfacing, operation outside of design limits, improper repair, or unauthorized modification. This WARRANTY is VOID if the unit shows evidence of having been tampered with or shows evidence of being damaged as a result of excessive corrosion; or current, heat, moisture or vibration; improper specification; misapplication; misuse or other operating conditions outside of NEWPORT's control. Components which wear are not warranted, including but not limited to contact points, fuses, and triacs.

**NEWPORT is pleased to offer suggestions on the use of its various products. However, NEWPORT neither assumes responsibility for any omissions or errors nor assumes liability for any damages that result from the use of its products in accordance with information provided by NEWPORT, either verbal or written. NEWPORT warrants only that the parts manufactured by it will be as specified and free of defects. NEWPORT MAKES NO OTHER WARRANTIES OR REPRESENTATIONS OF ANY KIND WHATSOEVER, EXPRESSED OR IMPLIED, EXCEPT THAT OF TITLE, AND ALL IMPLIED WARRANTIES INCLUDING ANY WARRANTY OF MERCHANTABILITY AND FITNESS FOR A PARTICULAR PURPOSE ARE HEREBY DISCLAIMED. LIMITATION OF LIABILITY: The remedies of purchaser set forth herein are exclusive and the total liability of NEWPORT with respect to this order, whether based on contract, warranty, negligence, indemnification, strict liability or otherwise, shall not exceed the purchase price of the component upon which liability is based. In no event shall NEWPORT be liable for consequential, incidental or special damages.**

CONDITIONS: Equipment sold by NEWPORT is not intended to be used, nor shall it be used: (1) as a "Basic Component" under 10 CFR 21 (NRC), used in or with any nuclear installation or activity; or (2) in medical applications or used on humans. Should any Product(s) be used in or with any nuclear installation or activity, medical application, or used on humans, or misused in any way, NEWPORT assumes no responsibility as set forth in our basic WARRANTY / DISCLAIMER language, and additionally purchaser will indemnify NEWPORT and hold NEWPORT harmless from any liability or damage whatsoever arising out of the use of the Product(s) in such a manner.

## Return Requests/Inquiries

Direct all warranty and repair requests/inquiries to the NEWPORT Customer Service Department. **BEFORE RETURNING ANY PRODUCT(S) TO NEWPORT, PURCHASER MUST OBTAIN AN AUTHORIZED RETURN (AR) NUMBER FROM NEWPORT'S CUSTOMER SERVICE DEPARTMENT (IN ORDER TO AVOID PROCESSING DELAYS).** The assigned AR number should then be marked on the outside of the return package and on any correspondence.

The purchaser is responsible for shipping charges, freight, insurance and proper packaging to prevent breakage in transit.

FOR **WARRANTY** RETURNS, please have the following information available **BEFORE** contacting NEWPORT:

1. P.O. number under which the product was **PURCHASED**,
2. Model and serial number of the product under warranty, and
3. Repair instructions and/or specific problems relative to the product.

FOR **NON-WARRANTY** REPAIRS, consult NEWPORT for current repair charges. Have the following information available **BEFORE** contacting NEWPORT:

1. P.O. number to cover the **COST** of the repair,
2. Model and serial number of product, and
3. Repair instructions and/or specific problems relative to the product.

NEWPORT's policy is to make running changes, not model changes, whenever an improvement is possible. This affords our customers the latest in technology and engineering.

NEWPORT is a registered trademark of NEWPORT Electronics, Inc.

© Copyright 2001 NEWPORT Electronics, Inc. All rights reserved. This document may not be copied, photocopied, reproduced, translated, or reduced to any electronic medium or machine-readable form, in whole or in part, without prior written consent of NEWPORT Electronics, Inc.

---

For immediate technical or application assistance please call:

**1-800-6397678<sup>®</sup>**  
**1-800-NEWPORT**

---

Newport Electronics, Inc.

2229 South Yale Street • Santa Ana, CA • 92704 • U.S.A.

TEL: (714) 540-4914 • FAX: (714) 546-3022

Toll Free: 1-800-639-7678 • <http://www.newportUS.com> • e-mail: [info@newportUS.com](mailto:info@newportUS.com)

ISO 9001 Certified

---

Newport Technologies, Inc.

976 Bergar • Laval (Quebec) • H7L 5A1 • Canada

TEL: (514) 335-3183 • FAX: (514) 856-6886

Toll Free: 1-800-639-7678 • <http://www.newport.ca> • e-mail: [sales@newport.ca](mailto:sales@newport.ca)

---

Newport Electronics, Ltd.

One Omega Drive • River Bend Technology Centre

Northbank, Irlam • Manchester M44 5BD • United Kingdom

Tel: +44 161 777 6611 • FAX: +44 161 777 6622

Toll Free: 0800 488 488 • <http://www.newportuk.co.uk> • e-mail: [sales@newportuk.co.uk](mailto:sales@newportuk.co.uk)

---

Newport Electronics B.V.

Postbus 8034 • 1180 LA Amstelveen • The Netherlands

TEL: +31 20 3472121 • FAX: +31 20 6434643

Toll Free: 0800 0993344 • <http://www.newport.nl> • e-mail: [sales@newport.nl](mailto:sales@newport.nl)

---

Newport Electronics spol s.r.o.

Rudé armády 1868, 733 01 Karviná 8 • Czech Republic

TEL: +420 69 6311899 • FAX: +420 69 6311114

Toll Free: 0800-1-66342 • <http://www.newport.cz> • e-mail: [sales@newport.cz](mailto:sales@newport.cz)

---

Newport Electronics GmbH

Daimlerstrasse 26 • D-75392 Deckenpfronn • Germany

TEL: 49 7056 9398-0 • FAX: 49 7056 9398-29

Toll Free: 0800 / 6397678 • <http://www.newport.de> • e-mail: [sales@newport.de](mailto:sales@newport.de)

---

Newport Electronique S.A.R.L.

11, rue Jacques Cartier • 78280 Guyancourt • France

TEL: +33 1 61 37 29 00 • FAX: +33 1 30 57 54 27

Toll Free: 0800 466 342 • <http://www.newport.fr> • e-mail: [sales@newport.fr](mailto:sales@newport.fr)

---

Mexico and Latin America

TEL: 001-800-826-6342 • FAX: 001 (203) 359-7807

En Español: 001 (203) 359-7803

<b>NEWPORTnet<sup>SM</sup> On-Line Service</b> <a href="http://www.newportUS.com">www.newportUS.com</a>	<b>Internet e-mail</b> <a href="mailto:info@newportUS.com">info@newportUS.com</a>
--	--



**NEWPORT** Electronics, Inc.