

Analog and Digital Output Signal Conditioners/Transmitters



\$250
iDRN/iDRX

Patented



- ✓ **ANALOG OR DIGITAL OUTPUTS**
- ✓ **Models Available for:**
Thermocouple
RTD
Process Voltage & Current
Strain
Frequency/Pulse
AC Voltage and Current
- ✓ **Up to 1800 Vdc Isolation**
- ✓ **iDRN Series Provide**
0-10 Vdc, 4-20 mA or
0-20 mA Output
- ✓ **iDRX Series Provide RS-485**
Output (ASCII Serial Protocol and
MODBUS Serial Protocol)
- ✓ **Free Setup and Configuration Software**
- ✓ **Factory Setup and Configuration Available at No Charge (for iDRN Analog Output Models)**

The new iD Series signal conditioners combine the accuracy of laboratory instrumentation with the performance required by demanding industrial applications. The iD Series signal conditioners are ideal for those applications in Data Acquisition, Test & Measurement, Process Control, and Industrial Automation where accuracy, performance, and reliability are critically important.

The iD Series signal conditioners mount on a 35mm DIN rail, and operate on any voltage between 10-32 Vdc power. (A matching 24 Vdc 850 mA switching power supply is also available.) The devices feature three-way isolation of up to 1800 V between the signal inputs, outputs, and power supply.

The iD series feature seven (7) models designed for each of the most widely measured signal inputs: Process (DC) Voltage and Current; Strain Gage; Thermocouples; RTD's; AC Voltage; AC Current; Frequency/Pulse.

The iD series devices are designed to work directly with a variety of sensors and transducers; no other components are necessary. For sensors such as RTD's, strain gages, and some process transducers, precise stable excitation is provided directly from the iD module.

The iD series are available with two different types of signal outputs: Analog or Digital. The **iDRN** series provides a totally scalable analog output in DC voltage or current. The **iDRX** series provide a digital RS-485 output. Both iD Series signal conditioners are intelligent microprocessor based instruments that can be scaled and programmed by computer via serial communications, or over an Ethernet network.

iDRN SERIES ANALOG OUTPUT

The **iDRN** series feature a 0-10 Vdc, or 0-20 mA (including 4-20 mA) analog output signal that is typically scaled to be directly proportional to the input signal. It is an ideal component in a system with PLC's or PC's with analog data acquisition boards.

The **iDRN** series are an excellent choice for applications that demand an extra measure of accuracy and performance that is not possible with conventional "analog" signal conditioners or transmitters. Unlike conventional analog devices that are scaled by adjusting zero and span "pots", the programmable, micro-processor based **iDRN** instruments are scaled precisely on a PC with free and simple Windows software. The **iDRN** modules connect directly to a PC's RS-232 Serial Communications port for programming and scaling.

Once the module is configured, the parameters are saved in non-volatile memory. The device can be disconnected from the PC, or the RS-232 output from the module can be used for continuous data acquisition in addition to the analog output.

Alternatively, the **iDRN** signal conditioner can be connected to a PC's Ethernet port or an Ethernet network using the **EIS-2B** module as a Serial/Ethernet bridge.

Analog and Digital Output Signal Conditioners/Transmitters

iD Series

FREE SETUP and CONFIGURATION

If an iDRN signal conditioner is not going to be connected to a computer, it can be ordered preconfigured by the factory at no extra charge. The user can select the input types, ranges and output scale, and NEWPORT will program the instruments to those specific requirements in our calibration lab prior to shipment. For custom factory setup and scaling of the iDRN model, please specify the "-FS" option.

DRX SERIES DIGITAL OUTPUT

The iDRX Series Signal Conditioners provide highly accurate digital outputs. Each module provides an RS-485 Serial output that can be transmitted directly to computers and other devices with serial communications capability, or converted to Ethernet.

On an RS-485 bus, up to 32 modules can be connected over a distance of 1200 m (4000 ft) on a single pair of wires. With optional RS-485 repeaters, up to 254 modules may be connected to a single RS-485 port. The iDRX Series digital conditioners may be connected to an RS-485 bus using either screw terminator or RJ-12 connector.

ASCII AND MODBUS

The user can select between an easy-to-use, straightforward ASCII protocol, or the popular MODBUS protocol found in many existing industrial installations. With the simple ASCII commands, writing programs using the iDRX does not require special drivers or libraries. In addition, many off-the-shelf software packages can be used with the iDRX devices without any programming. NEWPORT also provides a number of useful programs and demos for the iDRX at no charge.

OPC Server and Active X CONTROLS

NEWPORT offers an optional OPC Server (OLE for Process Control) to integrate the iDRX with OPC-Client data acquisition, process control and industrial automation software available from NEWPORT, Iconics, Intellution and Wonderware, among others. Or utilize the ActiveX controls to interact with iDRX in ActiveX Container software such as Microsoft Excel, Microsoft Visual Basic, Intellution, Rockwell Automation, and GE Fanuc CIMPLICITY among others.

iDRX and iDRN Series Common Specifications:

Input Power Supply: 10 to 32 Vdc

iDRX Output: 2-wire (half duplex) RS-485 (NEWPORT® ASCII Serial Protocol and Modbus Serial Protocol)

iDRN Output: 0 to 10 V @ 10 mA max; 0 to 20 mA or 4 to 20 mA, 10 V compliance

Isolation: 1800 V peak

Typical Step Response to 99%: 1 second

Operating Ambient: -5 to 55°C (23 to 131°F)

Storage Temperature Range: -40 to 85°C (-40 to 185°F)

Mounting: 35 mm DIN rail

Dimensions: 90 x 25 x 124 mm (3.54 x 0.99 x 4.88")



Mounts to 35 mm DIN rails.

| Input | Thermocouple | RTD | ac Voltage | ac Current | Process | Strain/Bridge | Frequency Pulse |
|---------------------------------|---|--|--------------------------------------|-----------------------------------|---|---|---|
| Model No. | iDRN/iDRX-TC | iDRN/iDRX-RTD | iDRN/iDRX-ACV | iDRN/iDRX-ACC | iDRN/iDRX-PR | iDRN/iDRX-ST | iDRN/iDRX-FP |
| Input Type | Thermocouple temperature sensor | RTD Temperature sensor Pt100, 500, 1000Ω | ac Voltage | ac Current | dc Millivolt, Volt and Current | Millivolt | NAMUR Contact closure low level open collector |
| Input Range | J, K, T, E, R, S, B, N, J DIN thermocouple full range | $\alpha = 385, 392$ Full range of RTD 2, 3 or 4-wire | Full Scale Range: 400 mV to 400 V | Full Scale Range: 10 mA to 5 A | Full Scale Range: ± 400 mV to ± 10 V 0 to 20 mA | 0 to 30 mV 0 to 100 mV ± 100 mV | Full Scale Range 20k to 0 to 200 M pulses 50 kHz |
| Accuracy | $\pm 1^\circ\text{C}$ | $\pm 0.5^\circ\text{C}$ | 0.2% | 0.2% | 0.1% FS | 0.2% FS | 0.1% FS |
| Resolution | 0.1°C | 0.1°C | 10 to 14 Bit | 10 to 14 Bit | 12 to 15 Bit | 13 to 15 Bit | 15 to 19 Bit |
| Output | iDRX Series: 2-wire (half duplex) RS-485/iDRN Series: 0 to 10 V @ 10 mA max; 0 to 20 mA or 4 to 20 mA | | | | | | |
| Excitation | N/A | N/A | N/A | N/A | 14 Vdc @ 25 mA | 10 V @ 30 mA | 5, 8.2 and 12.5 Vdc @ 25 mA |
| iDRN RS-232 & ANALOG | \$325 | \$355 | \$345 | \$345 | \$325 | \$345 | \$295 |
| iDRX RS-485 | \$250 | \$250 | \$270 | \$270 | \$275 | \$300 | \$250 |

Analog and Digital Output Signal Conditioners/Transmitters

iD Series



ETHERNET and INTERNET

The **iDRX** signal conditioner can also be connected to an Ethernet network using the **EIS-2B** module as a Serial/Ethernet bridge. One **EIS-2B** module can be a hub for up to 32 **iDRX** modules. The **EIS-2B** module packages the ASCII serial communications in standard TCP/IP Protocol for transmission over standard Ethernet networks and the Internet. Unlike some manufacturer's products this system uses totally open, non-proprietary standards and protocols for Ethernet and Internet. The user can integrate these devices with any commercial or industrial grade networking components that also comply with the popular international standards.

Access Vital information Anytime, Anywhere, on the World Wide Web

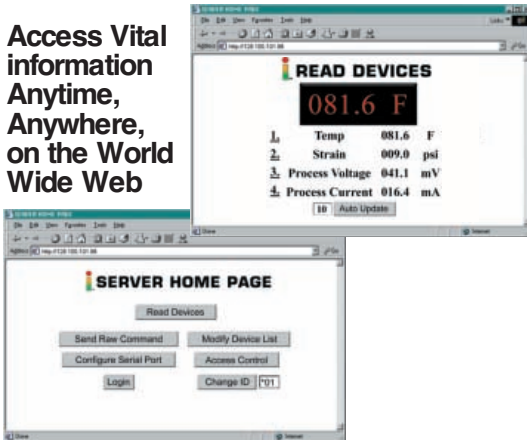

Get Internet E-mail Notification of Alarm Status on your web enabled phone or PDA.

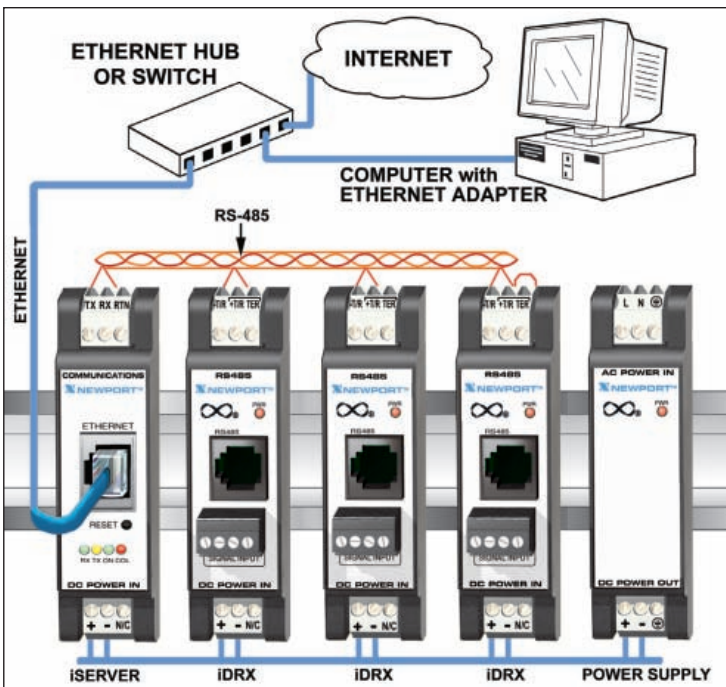

Digital Output iDRX modules connected to Ethernet

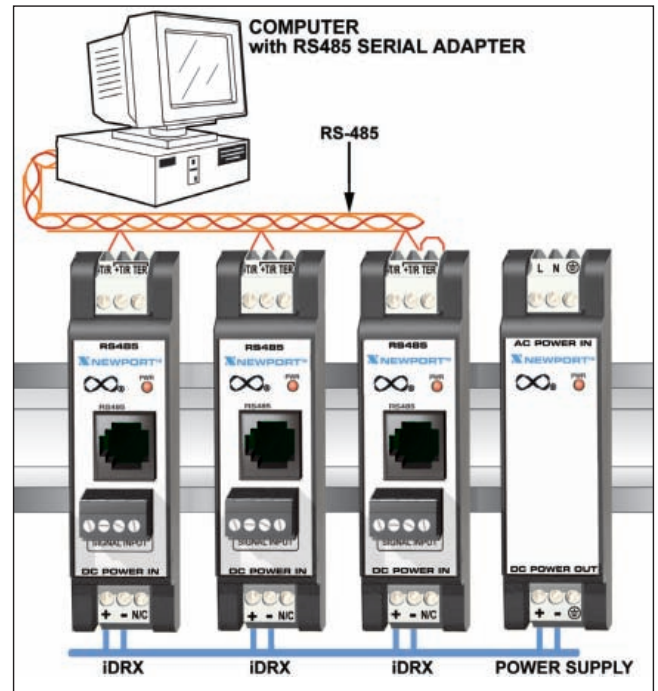

iDRX modules on RS485 Serial Bus

Thermocouple Signal Conditioners

iD Series



- ✓ T/C Types J, K, T, E, R, S, B, N, J DIN
- ✓ 0.1°C Resolution
- ✓ ±1°C Accuracy
- ✓ 1800 V Isolation
- ✓ 250 V/1 Min. Input Overvoltage Protection
- ✓ Free Setup and Configuration Software
- ✓ Factory Setup and Configuration Available at No Charge (for iDRN Analog Output Models)

\$250
IDRX-TC



NEWPORT manufactures many types of thermocouple probes. Refer to our website www.newportUS.com

The iDRN-TC and iDRX-TC signal conditioners provide highly accurate, stable, isolated measurement of thermocouple sensors.

Thermocouple types are selected and the outputs are scaled with the free configuration software, or can be done at the factory for no additional charge. The T/C Signal Conditioners can accept 9 different thermocouple types: J, K, T, E, R, S, B, N, and J DIN.

TWO MODELS: ANALOG or DIGITAL OUTPUTS

iDRN-TC provides an analog output that is proportional to the input signal. The iDRX-TC uses a digital RS-485 communication link.

ANALOG OUTPUT MODEL

The output of iDRN-TC can be user set for 0 to 10 V, 4 to 20 mA or 0 to 20 mA. Input scaling and configuration of other operating parameters is accomplished by connecting to a standard RS-232 port of a personal computer and using the free Windows-based setup software. Once configured the settings may be stored in non-volatile memory and the unit disconnected from the PC.

Factory Setup and Configuration at No Extra Charge (iDRN Analog Output Model)

Please Specify:

- Thermocouple Type
- Temperature High & Low
- Output Value High & Low
- Example:** Type J, 0°C = 4mA, 100°C = 20mA

DIGITAL OUTPUT MODEL

The iDRX-TC is a digital signal conditioner which communicates over an RS-485 communication link using either a simple, straightforward NEWPORT® ASCII Serial Protocol or MODBUS Serial Protocol. Up to 32 modules may be connected to a single RS-485 port stretching up to 4,000 ft. without repeaters.

ETHERNET CONNECTION

The Optional EIS-2B iServer module can connect up to thirty-two (32) iDRX RS-485 Signal Conditioners to an Ethernet network and the Internet using standard TCP/IP protocol. The iServer can also be used as a simple Serial to Ethernet "bridge" or converter to connect a single iDRN RS-232 device to an Ethernet network and the Internet.

Specifications

- Accuracy at 25°C:** ±1°C
- Resolution:** 0.1°C
- Power Consumption:** 2 W (84 mA @ 24 Vdc)
- Input Types:** J, K, T, E, R, S, B, N, J DIN
- Input Ranges:** See range chart
- iDRX Output:** 2-wire (half duplex) RS-485 (NEWPORT® ASCII Serial Protocol and MODBUS SERIAL Protocol)
- iDRN Output:** 0 to 10 V @ 10 mA max; 0 to 20 mA or 4 to 20 mA, 10 V compliance
- Thermocouple Default settings iDRN:** Input Type K, Range 0-1000 °F; Output 4-20 mA (Custom Settings available at no charge.)

| Input Type | Range, °F | Range, °C |
|------------|----------------|----------------|
| J | -346 to 1400°F | -210 to 760°C |
| K | -454 to 2500°F | -270 to 1372°C |
| T | -454 to 752°F | -270 to 400°C |
| E | -454 to 1832°F | -270 to 1000°C |
| R S | -58 to 3214°F | -50 to 1768°C |
| B | +212 to 3300°F | +100 to 1820°C |
| N | -454 to 2372°F | -270 to 1300°C |
| J DIN | -328 to 1652°F | -200 to 900°C |

| To Order (Specify Model Number) | | |
|---------------------------------|-------|--|
| Model No. | Price | Description |
| iDRX-TC | \$250 | Digital signal conditioner with RS-485 output for Thermocouple sensors |
| iDRN-TC | \$325 | Signal conditioner with analog output for Thermocouple sensors |
| -FS | Free | Factory setup and scaling |

Each unit supplied with complete operator's manual.
Ordering Example: iDRN-TC signal conditioner (\$325), and DB9-RJ12 connector adapter (\$30), \$325 + \$30 = \$355.

RTD Signal Conditioners

iD Series



\$250
iDRX-RTD

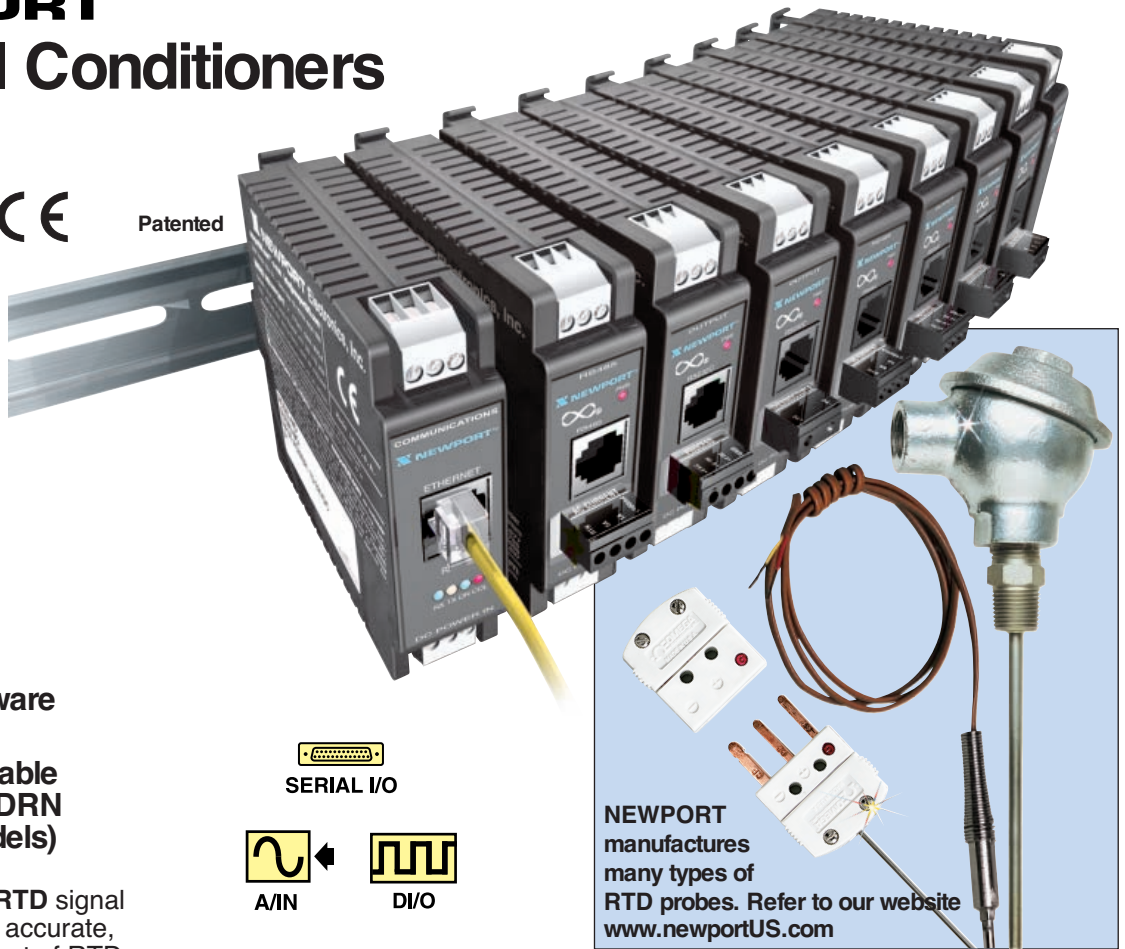

- ✓ 100Ω Pt, 500Ω Pt, 1000Ω Pt RTDs
- ✓ 0.1°C Resolution
- ✓ ±0.5°C Accuracy
- ✓ 1800 V Isolation
- ✓ Free Setup and Configuration Software
- ✓ Factory Setup and Configuration Available at No Charge (for iDRN Analog Output models)

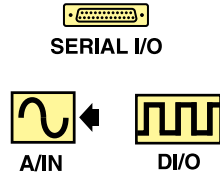

The iDRN-RTD and iDRX-RTD signal conditioners provide highly accurate, stable, isolated measurement of RTD temperature sensors. Both models can accept 2, 3, or 4 wire 100Ω PT, 500Ω PT, and 1000Ω PT RTDs.

TWO MODELS: ANALOG or DIGITAL OUTPUTS

The iDRN-RTD provides a fully scalable analog output that is proportional to the input signal. The iDRX-RTD uses digital RS-485 communications.

ANALOG OUTPUT MODEL

The output of the iDRN-RTD can be user set for 0 to 10 V, 4 to 20 mA or 0 to 20 mA. Input scaling and configuration of other operating parameters is accomplished by connecting to a standard RS-232 port of a personal computer and using the Windows-based setup software. Once configured the settings may be stored in non-volatile memory and the unit disconnected from the PC.

Factory Setup and Configuration at No Extra Charge (iDRN Analog Output Model)

Please Specify:

Type & Resistance
Temperature High & Low
Output Value High & Low

Example: Type Pt100; 0.00385;
4-wire; 0°C = 4 mA, 100°C = 20 mA

DIGITAL OUTPUT MODEL

The iDRX-RTD is a digital signal conditioner which communicates over an RS-485 communication link using either a simple, straightforward NEWPORT® ASCII Serial Protocol or MODBUS Serial Protocol. Up to 32 modules may be connected to a single RS-485 port stretching up to 4,000 ft. without repeaters.

ETHERNET CONNECTION

The Optional EIS-2B iServer module can connect up to thirty-two (32) iDRX RS-485 Signal Conditioners to an Ethernet network and the Internet using standard TCP/IP protocol. The iServer can also be used as a simple Serial to Ethernet "bridge" or converter to connect a single iDRN RS-232 device to an Ethernet network and the Internet.

NEWPORT manufactures many types of RTD probes. Refer to our website www.newportUS.com

Specifications

- Accuracy at 25°C:** ±0.5°C
- Input Types:** Platinum RTD, 100Ω, 500Ω or 1000Ω element (2, 3 or 4 wire, 385 or 392 curve)
- Resolution:** 0.1°C
- Power Consumption:** 2.4 W (100 mA @ 24Vdc)
- Input Range:** -200 to 850°C (-328 to 1562°F)
- iDRX Output:** 2-wire (half duplex) RS-485 (NEWPORT® ASCII Serial Protocol and MODBUS Serial Protocol)
- iDRN Output:** 0-to-10 V @ 10 mA max; 0 to 20 mA or 4 to 20 mA, 10 V compliance
- RTD Default settings iDRN:** Input PT100, .00385, 3-wire, Range 0-1000°F; Output 4-20 mA (Custom Settings available at no charge.)

To Order (Specify Model Number)

| Model No. | Price | Description |
|-----------|-------|---|
| iDRX-RTD | \$250 | Digital signal conditioner with RS-485 output for RTD Temperature Sensors |
| iDRN-RTD | \$355 | Signal conditioner with analog output for RTD Temperature Sensors |
| -FS | Free | Factory setup and scaling |

Each unit supplied with complete operator's manual.

Ordering Example: iDRN-RTD digital signal conditioner (\$355), and DB9-RJ12 connector adapter (30), \$355 + 30 = \$385.

For iDRN/iDRX accessories and power supplies, please see start of this section.

Process Inputs Signal Conditioners

iD Series

- ✓ Unipolar/Bipolar 400 mV to 10 Vdc, 0 to 20 mA dc
- ✓ 11 to 14-Bit Resolution
- ✓ ±0.1% FS Accuracy
- ✓ 14 Vdc Excitation
- ✓ 1800 V Isolation
- ✓ 250 Vac/1 Min. Input Overvoltage Protection (Voltage Input Only)
- ✓ Free Setup and Configuration Software
- ✓ Factory Setup and Configuration Available at No Charge (for iDRN Analog Output models)



Patented

\$275
iDRX-PR

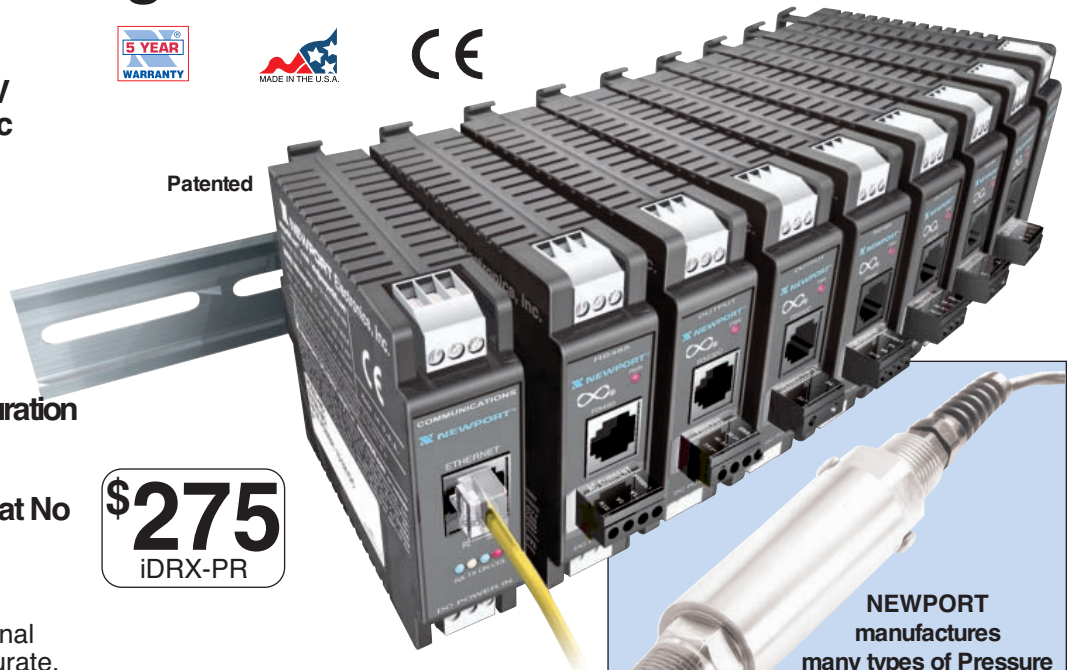

NEWPORT manufactures many types of Pressure Transducers. Refer to our website www.newportUS.com



The **iDRN-PR** and **iDRX-PR** signal conditioners provide highly accurate, stable, isolated measurement of process signals. Both models can accept unipolar and bipolar signals from 400 mV to 10 Vdc full scale, as well as 0 to 20 mA current range. The Signal Conditioners also provide a 10Vdc or 14 Vdc reference voltage which can be used for transducer excitation.

TWO MODELS: ANALOG or DIGITAL OUTPUTS

The **iDRN-PR** provides a programmable analog output that is proportional to the input signal. The **iDRX-PR** uses a digital RS-485 Serial Communications.

ANALOG OUTPUT MODEL

The output of **iDRN-PR** can be user set for 0 to 10 V, 4 to 20 mA or 0 to 20 mA. Scaling and configuration is done with the free software on a PC using either the standard RS-232 port, or an Ethernet connection with the optional **EIS-2B** module. Once configured the settings are stored in non-volatile memory and the unit disconnected from the PC.

Factory Setup and Configuration at No Extra Charge (iDRN Analog Output model)

Please Specify:

Input Value High & Low
Output Value High & Low
Excitation: 10 or 14 Volts dc
Ratiometric or Non-Ratiometric
Example: 0 V = 4 mA, 10 V = 20 mA,
Excitation 10 V, Non-Ratiometric

DIGITAL OUTPUT MODEL

The **iDRX-PR** is a digital signal conditioner which communicates over an RS-485 communication link using either a simple straightforward NEWPORT® ASCII Serial Protocol or MODBUS Serial Protocol. Up to 32 modules may be connected to a single RS-485 port stretching up to 4,000 ft. without repeaters.

ETHERNET CONNECTION

The Optional **EIS-2B** iServer module can connect up to thirty-two (32) **iDRX** RS-485 Signal Conditioners to an Ethernet network and the Internet using standard TCP/IP protocol. The iServer can also be used as a simple Serial to Ethernet "bridge" or converter to connect a single **iDRN** RS-232 device to an Ethernet network and the Internet.

Specifications

Accuracy at 25°C: ±0.1% FS
Excitation: 14 Vdc @ 25 mA
Resolution: 11 to 14-bit
Power Consumption: 2 W (84 mA @ 24 Vdc) without excitation, 3 W (125 mA @ 24 Vdc) with excitation
Input Ranges: Uni/bipolar, 400 mV to 10 Vdc; 0 to 20 mA
iDRX Output: 2-wire (half duplex) RS-485 (NEWPORT® ASCII Serial Protocol and MODBUS Serial Protocol)
iDRN Output: 0 to 10 V @ 10 mA max; 0 to 20 mA or 4 to 20 mA, 10 V compliance
Process Default settings DRN: Input Range 0-20mA; Output 4-20mA. Excitation 14V (Custom Settings available at no charge.)

To Order (Specify Model Number)

| Model No. | Price | Description |
|-----------|-------|---|
| iDRX-PR | \$275 | Digital signal conditioner with RS-485 output for process signals |
| iDRN-PR | \$325 | Signal conditioner with analog output for process signals |
| -FS | Free | Factory setup and scaling |

Each unit supplied with complete operator's manual.

Ordering Example: iDRX-PR digital signal conditioner with RS-485 output for process signals (\$275), plus iDRN-PS-1000 power supply, 95-240 Vac input, 24 Vdc output @ 850 mA (\$150), \$275 + 150 = \$425

For iDRN/iDRX accessories and power supplies, please see start of this section.

Strain Gage/Bridge Transducer-Signal Conditioners

iD Series



\$300
iDRX-ST



NEWPORT manufactures many types of Load Cells. Refer to our website www.newportUS.com

- ✓ Unipolar/Bipolar 30 mV to 100mV
- ✓ 13-Bit Resolution
- ✓ 10 Vdc Excitation
- ✓ 0.2% FS Accuracy
- ✓ 1800 Volts Isolation
- ✓ 250 Vac/1 Min. Input Overvoltage Protection
- ✓ Free Setup and Configuration Software
- ✓ Factory Setup and Configuration Available at No Charge (for iDRN Analog Output models)

The iDRN-ST and iDRX-ST signal conditioners provide highly accurate, stable, isolated measurement for strain gage transducers such as load cells, torque transducers, non-amplified pressure transducers, and other bridge based transducers. Both models can accept signals from 30 to 100 mV full scale and provide 10 Vdc reference voltage which may be used for transducer excitation.

TWO MODELS: ANALOG or DIGITAL OUTPUTS

The iDRN-ST provides an analog output that is proportional to the input signal and the iDRX-ST uses RS-485 Serial Communications.

ANALOG OUTPUT MODEL

The output of iDRN-ST can be user set for 0 to 10 V, 4 to 20 mA or 0 to 20 mA. Input scaling and configuration of other operating parameters is accomplished by connecting to a standard RS-232 port of a personal computer and using the free Windows-based setup software. Once configured the settings may be stored in non-volatile memory and the unit disconnected from the PC.

Factory Setup and Configuration at No Extra Charge (iDRN Analog Output and RS-232 signal conditioners)

Please Specify:

- Input Value High & Low
- Output Value High & Low
- Excitation: 10 or 14 Volts dc
- Ratiometric or Non-Ratiometric
- Example:** 0 V = 4 mA, 100 mV = 20 mA, Excitation 10 V, Ratiometric

DIGITAL OUTPUT MODEL

The iDRX-ST is a digital signal conditioner which communicates over RS-485 communication link using either a simple NEWPORT® ASCII Protocol or MODBUS Protocol. Up to 32 modules may be connected to a single RS-485 port stretching up to 4,000 feet without repeaters.

ETHERNET CONNECTION

The Optional EIS-2B iServer module can connect up to thirty-two (32) iDRX RS-485 Signal Conditioners to an Ethernet network and the Internet using standard TCP/IP protocol. The iServer can also be used as a simple Serial to Ethernet "bridge" or converter to connect a single iDRN RS-232 device to an Ethernet network and the Internet.

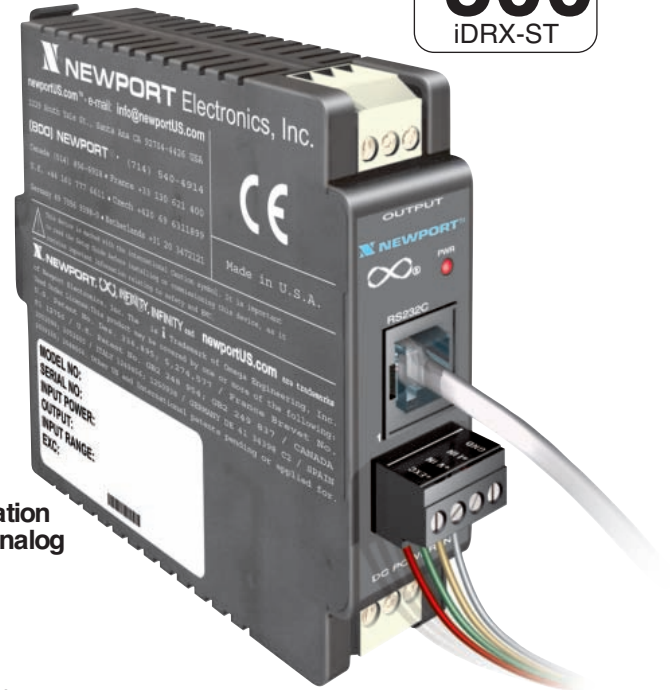

Specifications

- Accuracy at 25°C:** ±0.2% FS
- Resolution:** 13 to 15 bit
- Excitation:** 10 V @ 30 mA
- Power Consumption:** 2 W without excitation (84 mA @ 24 Vdc), 3 W with excitation (125 mA @ 24 Vdc)
- Input Ranges:** 0 to 30 to 0 to 100 mV full scale
- iDRX Output:** 2-wire (half duplex) RS-485 (NEWPORT® ASCII Serial Protocol and MODBUS Serial Protocol)
- iDRN Output:** 0 to 10 V @ 10 mA max; 0 to 20 mA or 4 to 20 mA, 10 V compliance
- Strain Default settings iDRN:** Input Range 0-30mV; Output 4-20mA. Excitation 10V Ratiometric (Custom Settings available at no charge.)

| To Order (Specify Model Number) | | |
|--|--------------|---|
| Model No. | Price | Description |
| iDRX-ST | \$300 | Digital signal conditioner for strain gages and bridge transducers with RS-485 output |
| iDRN-ST | \$345 | Signal conditioner for strain gages and bridge transducers with analog output |
| -FS | Free | Factory setup and scaling |

Each unit supplied with complete operator's manual.

Ordering Example: iDRX-ST digital signal conditioner for strain gages and bridge transducers with RS-485 output (\$300), plus CAT-285 bi-directional RS-232-RS-485 converter for iDRX series (\$148), \$300 + 148 = \$448.

For iDRN/iDRX accessories and power supplies, please see start of this section.

Frequency/Pulse Digital Signal Conditioners

iD Series

- ✓ Software Selectable Input Type
- ✓ 0 to 50 KHz Frequency Input
2 Million Pulse Capacity
- ✓ Proximity, Switch, Magnetic, Pickup, NAMUR, Contact Closure and Open Collector Input Types
- ✓ RS-485 Output
- ✓ 1800 V Isolation
- ✓ Free Setup and Configuration Software
- ✓ Factory Setup and Configuration Available at No Charge (for iDRN Analog Output models)



\$250
iDRX-FP



NEWPORT manufactures many types of Flow Transducers. Refer to our website www.newportUS.com

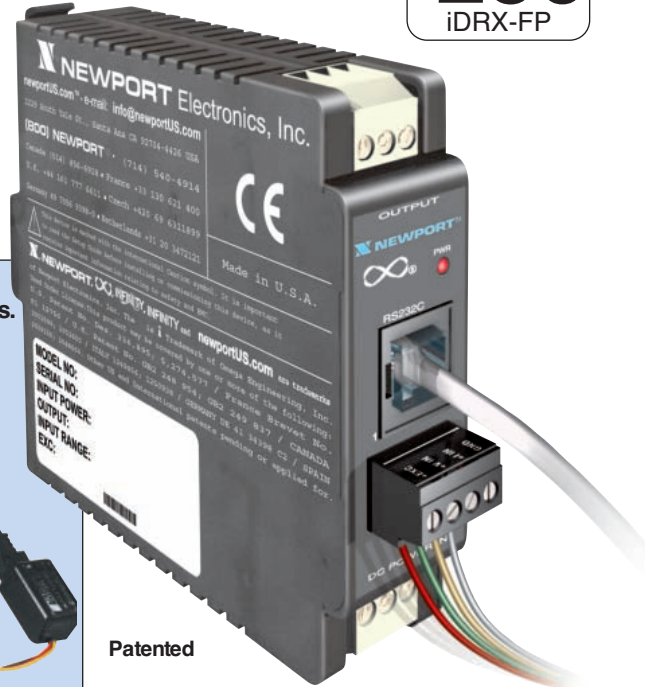

Patented

The iDRN-FP and iDRX-FP signal conditioners provide accurate, stable, isolated measurement of frequency and pulse signals. Both models measure frequency signals up to 50 KHz and can count up to two million pulses. The iDRX-FP and iDRN-FP are compatible with a wide variety of transducers including proximity, switch, magnetic pickup, NAMUR, contact closure and open collector transducers.

TWO MODELS: ANALOG or DIGITAL OUTPUTS

The iDRN-FP provides an analog output that is proportional to the input signal. The iDRX-FP uses digital RS-485 Serial Communication.

ANALOG OUTPUT MODEL

The output of iDRN-FP can be user set for 0 to 10 V, 4 to 20 mA or 0 to 20 mA. Scaling and configuration is done with the free software on a PC using either the standard RS-232 port, or an Ethernet connection with the optional EIS-2B module. Once configured the settings are stored in non-volatile memory and the unit disconnected from the PC.

Factory Setup and Configuration at No Extra Charge (iDRN Analog Output signal conditioners)

Please Specify:
 Input Signal or Sensor Type
 Input Frequency High & Low
 Output Value High & Low
 Excitation: 10 or 14 Volts dc
 Magnetic Pickup (2-wire)
Example: 0 Hz = 4 mA,
 1000 Hz = 20mA, Excitation N/A

DIGITAL OUTPUT MODEL

The iDRX-FP is a digital signal conditioner which communicates over an RS-485 communication link using either a simple straightforward NEWPORT® ASCII Serial Protocol or MODBUS Serial Protocol. Up to 32 modules may be connected to a single RS-485 port stretching up to 4,000 ft. without repeaters.

ETHERNET CONNECTION

The Optional EIS-2B iServer module can connect up to thirty-two (32) iDRX RS-485 Signal Conditioners to an Ethernet network and the Internet using standard TCP/IP protocol. The iServer can also be used as a simple Serial to Ethernet "bridge" or converter to connect a single iDRN RS-232 device to an Ethernet network and the Internet.

Specifications

- Accuracy at 25°C:** ±0.1% FS
- Resolution:** 15 to 19-bit
- Power Consumption:** 2.4 W (100 mA @ 24 Vdc) without excitation, 3 W (125 mA @ 24 Vdc) with excitation
- Input Ranges:** Frequency from 200 Hz to 50 KHz pulse from 20,000 to 200,000,000 (200M) pulses full scale
- iDRX Output:** 2-wire (half duplex) RS-485 (NEWPORT® ASCII Serial Protocol and MODBUS Serial Protocol)
- iDRN Output:** 0 to 10 V @ 10 mA max; 0 to 20 mA or 4 to 20 mA
- FP Default settings iDRN:** Input 0-20 KHz; Output 4-20 mA (Custom Settings available at no charge.)

| To Order (Specify Model Number) | | |
|---------------------------------|-------|--|
| Model No. | Price | Description |
| iDRX-FP | \$250 | Digital signal conditioner with RS-485 output for Frequency/Pulse inputs |
| iDRN-FP | \$295 | Signal conditioner with analog output for Frequency/Pulse inputs |
| -FS | Free | Factory setup and scaling |

Each unit supplied with complete operator's manual.
Ordering Example: iDRN-FP signal conditioner (\$295), and DB9-RJ12 connector adapter (\$30), \$295 + \$30 = \$325.

For iDRN/iDRX accessories and power supplies, please see start of this section.

AC Voltage/Current Signal Conditioners

\$270
iDRX-ACV

iD Series

- ✓ **Software Selectable Input Ranges iDRX-ACV:**
0 to 400 mV to 0 to 400 Vac
- ✓ **iDRX-ACC: 0 to 10 mA to 0 to 5 A ac**
- ✓ **14-Bit Resolution (max)**
- ✓ **0.2% FS Accuracy**
- ✓ **1800 V Isolation**
- ✓ **Free Setup and Configuration Software**
- ✓ **Factory Setup and Configuration Available at No Charge (for iDRN Analog Output models)**

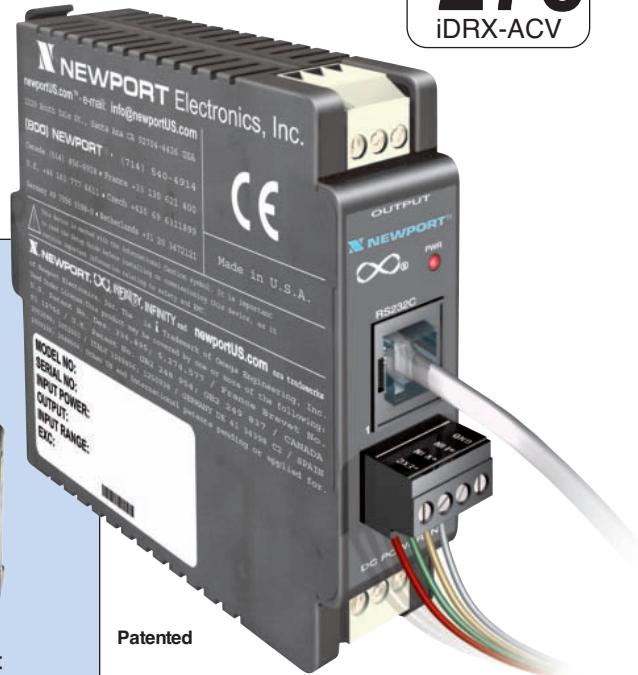

The **iDRN** and **iDRX** Series signal conditioners provide highly accurate, stable and isolated measurement of AC voltage and current signals across extremely wide ranges: AC Current ranges from 0 to 10 mA through 0 to 5 A ac; AC Voltage ranges from 0 to 400 mV to 0 to 400 Vac.

ANALOG or DIGITAL OUTPUTS

The **iDRN-ACV** and **iDRN-ACC** accept ac voltage and ac current respectively and provide an analog output which is proportional to the input. The **iDRX-ACV** and **iDRX-ACC** accept ac voltage and ac current respectively and transmit via RS-485 Serial Communications.

ANALOG OUTPUT MODEL

The Analog Output models can be configured for outputs of 0 to 10 Vdc, 4 to 20 mA or 0 to 20 mA with the free configuration software. The modules connect to a PC with RS-232 Serial Communications, or by Ethernet with the optional **EIS-2B** module. Once configured the settings are stored in non-volatile memory and the unit can be disconnected from the PC.

Factory Setup and Configuration at No Extra Charge (iDRN Analog Output Modules)

Please Specify:

iDRN-ACV: Input Value High & Low
Output Value High & Low

Example: 0 volts = 4 mA,
400Vac = 20 mA

iDRN-ACC: Input Value High & Low
Output Value High & Low

Example: 0 A = 4 mA, 5 A = 20 mA

DIGITAL OUTPUT MODEL

The **iDRX-ACC** (Current) and **iDRX-ACV** (Voltage) communicate via RS-485 Serial Communications using either simple NEWPORT® ASCII Commands or the popular MODBUS Protocol. Up to 32 modules may be connected to a single RS-485 port stretching up to 4,000 ft., more with RS-485 repeaters.

ETHERNET CONNECTION

The Optional **EIS-2B** iServer module can connect up to thirty-two (32) **iDRX** RS-485 Signal Conditioners to an Ethernet network and the Internet using standard TCP/IP protocol. The iServer can also be used as a simple Serial to Ethernet "bridge" or converter to connect a single **iDRN** RS-232 device to an Ethernet network and the Internet.

Patented

Specifications

Accuracy at 25°C: ±0.2% FS

Resolution: 10 to 14-bit

Power Consumption: 2.4 W;
(100 mA @ 24 Vdc)

MODEL iDRX-ACV/iDRN-ACV

Input Ranges: 0 to 400 mV to 0 to 400 Vac full scale

Interface: RS-485; RJ-12 or screw terminal connector

MODEL iDRX-ACC/ACC

Input Ranges: 0 to 10 mA to 0 to 5 A ac full scale

iDRX Output: 2-wire (half duplex) RS-485 (NEWPORT® ASCII Serial Protocol and MODBUS Serial Protocol)

iDRN Output: 0 to 10 V@10 mA max; 0 to 20 mA or 4 to 20 mA

ACV Default settings iDRN: Input 0-400 VAC; Output 4-20 mA (Custom Settings available at no charge.)

ACC Default settings iDRN: Input 0-5 Amp; Output 4-20 mA (Custom Settings available at no charge.)

To Order (Specify Model Number)

| Model No. | Price | Description |
|-----------------|--------------|--|
| iDRX-ACC | \$270 | Digital signal conditioner with RS-485 output for ac current input |
| iDRX-ACV | \$270 | Digital signal conditioner with RS-485 output for ac voltage input |
| iDRN-ACC | \$345 | Signal conditioner with analog output for ac current inputs |
| iDRN-ACV | \$345 | Signal conditioner with analog output for ac voltage inputs |
| -FS | Free | Factory setup and scaling |

Each unit supplied with complete operator's manual.

Ordering Example: iDRN-ACV signal conditioner (\$345), and DB9-RJ12 connector adapter (\$30), \$345 + 30 = \$375.

For iDRN/iDRX accessories and power supplies, please see start of this section.

NEWPORT® Switching Power Supply

- ✓ 24 Vdc Supply for iDRN/iDRX Modules
- ✓ iDRN-PS-1000 Switching Supply Powers up to 7 Units

iDRN-PS-1000

| Model No. | Price | Description |
|--------------------|-------|--|
| iDRN-PS-1000 | \$150 | Power Supply (switching), 95 to 240 Vac input, 24 Vdc output @ 850 mA (power 7 units) |
| SOFTWARE | | |
| OPC-SERVER LICENSE | \$295 | OPC Server for Signal Conditioners |
| iDRX-RS485-SW | Free | Active X Controls and Configuration Software/iDRX Windows 95/98/NT/XP. Free Sample Visual Basic App Source Code. |
| iDRN-RS232-SW | Free | Active X Controls and Configuration Software/iDRN Windows 95/98/NT. Free Sample Visual Basic App Source Code. |
| -FS | Free | Factory setup and scaling |
| ACCESSORIES | | |
| CAT-285 | \$148 | Bi-directional RS-232-R3-485 converter for DRX series |
| DB9-RJ12 | \$30 | DB9 to RJ12 Connector Adapter, includes 7ft. RJ12 cord |
| DB25-RJ12 | \$30 | DB25 to RJ12 Connector Adapter, includes 7ft. RJ12 cord |
| RJ12T | \$15 | RJ12“T” Split Connector for RS-485 instruments, includes 7 ft. RJ12 cord |



\$150
iDRN-PS-1000

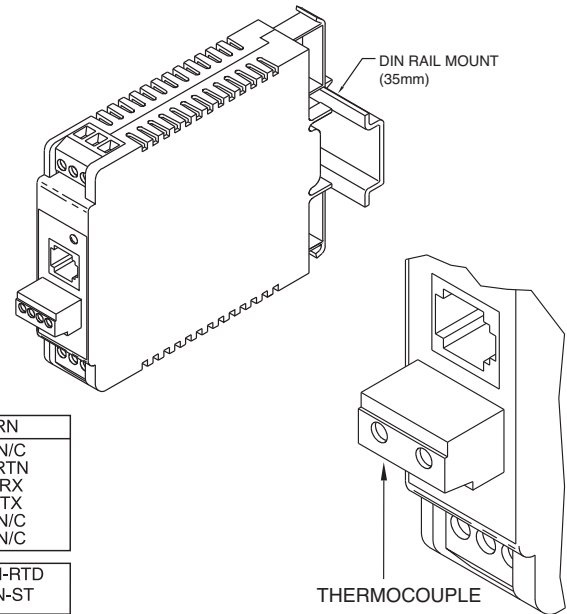
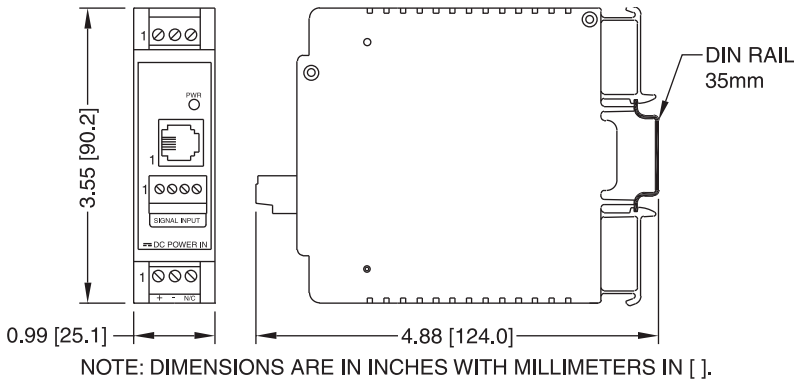

iDRN CONNECTIONS

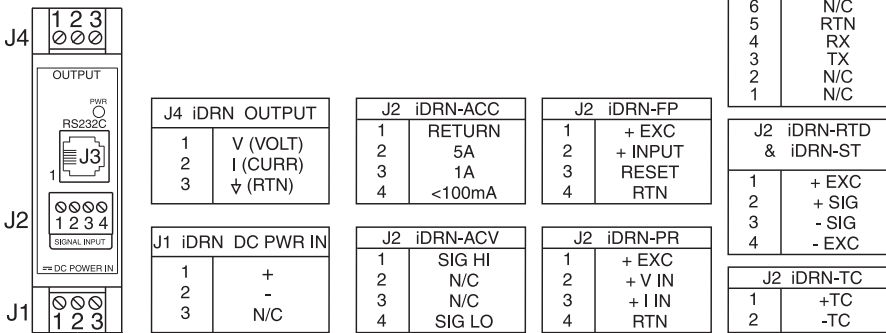

iDRX CONNECTIONS

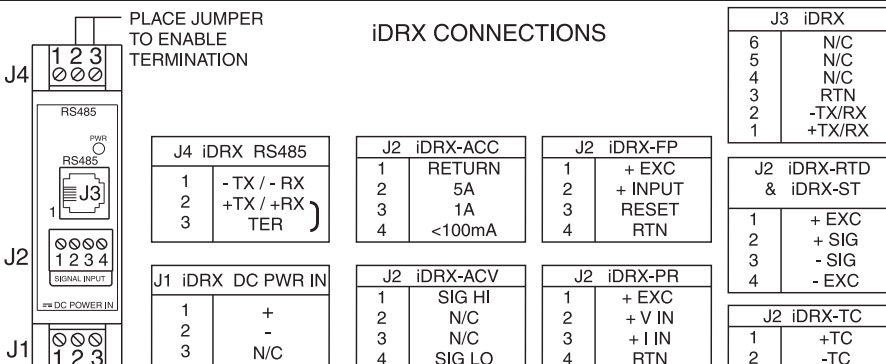

iDRN-PS-1000 CONNECTIONS

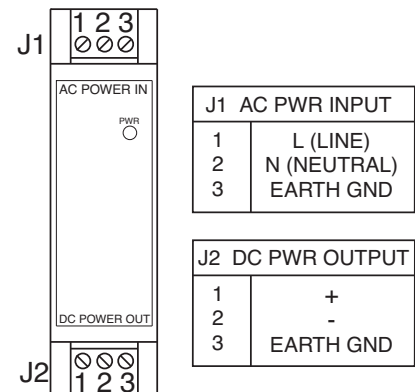

OPC Server Software

OPC

- ✔ Makes it easy to use NEWPORT hardware with popular software from:
 - OMEGA
 - Wonderware
 - iconics
 - Intellution
 - Rockwell Automation
 - National Instruments
 - ... and more!
- ✔ Download free trial at www.newportUS.com/software



The NEWPORT OPC Server software makes it easy to integrate NEWPORT hardware with software programs that are OPC compliant. The NEWPORT OPC Server is compatible with almost all NEWPORT meters, controllers, and signal conditioners featuring Ethernet or Serial Communications.

The NEWPORT OPC Server is available on CD-ROM or can be downloaded at no charge from the NEWPORT Web site. Without the License Activation Code, the free program will time-out after two (2) hours. These two-hour sessions can be repeated as often as necessary to evaluate the software at no charge.

To activate this license, you must first download the program or install from CD-ROM, and provide NEWPORT with the unique Installation Specific Code that will be presented within the installation process. If you choose to purchase a license On-Line, include this Installation Specific Code number in the "special instructions" for your order. As soon as possible during normal business hours, or the next business day, NEWPORT will provide you with the specific License Activation Code.

What is an OPC Server?

OPC Servers are hardware drivers that are written to a common standard, OPC or "OLE for Process Control". OPC compliant programs (OPC Clients) for HMI, SCADA, DAS, etc. are available from NEWPORT, OMEGA, Wonderware, iconics, Intellution, Rockwell Automation, and National Instruments, among others.

The OPC Foundation offers this explanation: "OPC (originally OLE for Process Control) is an industry standard created with the collaboration of a number a leading worldwide automation and hardware software suppliers working in cooperation with Microsoft.

The standard defines method for exchanging realtime automation data among PC-based clients using Microsoft operating systems. The organization that manages this standard is the OPC Foundation.

The OPC Specification is a non-proprietary technical specification that defines a set of standard interfaces based upon Microsoft's OLE/COM technology. The application of the OPC standard interface makes possible interoperability between automation/control applications, field systems/devices and business/office applications.

"Traditionally, each software or application developer was required to write a custom interface, or server/driver, to exchange data with hardware field devices. OPC eliminates this requirement by defining a common, high performance interface that permits this work to be done once, and then easily reused by HMI, SCADA, Control and custom applications.



An unlimited runtime version of the OPC Server Software requires purchase of a license and entry of a unique License Activation Code. Without this code, the free OPC Server program will time-out after two (2) hours.

| SOFTWARE (Requires Network Option) | | Price |
|------------------------------------|------------------------------------|-------|
| OPC-SERVER LICENSE | OPC Server/Driver Software License | \$295 |